

Electrical connections

Model 4WRA...2XJ/...(Without built-in amplifier)

Component plug connection form

The plug-in connector to DINEN 175301-803 or ISO4400

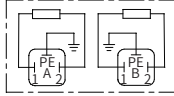

Component plug connection form

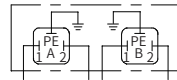

Model 4WRAE...2XJ/...(With built-in amplifier)

The plug-in connector to DINEN 175201-804

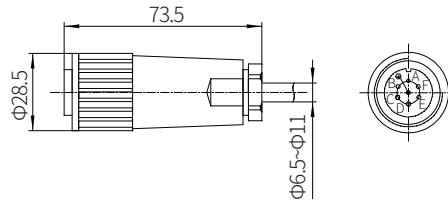

Model 4WRAE...(With built-in amplifier)

Terminal identification of plugs

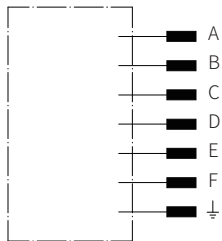

Terminal identification	contact	A1 signal	F1 signal
Supply voltage	A	24VDC(19~35V)	
	B	GND	
	C	no connection ¹⁾	
Differential amplifier input	D	±10V, Re>50K Ω	4~20mA, Re>100 Ω
	E	Reference potential	
	F	no connection ¹⁾	

Command value:

A positive command value 0 to +10V (or 12 to 20mA) at D and E causes a flow from P to A and B to T.

A negative command value 0 to -10V (or 12 to 4mA) at D and E causes a flow from P to B and A to T.

For valves only with one solenoid in side "A" (symbols EA and WA), a positive command value at D and E causes a flow from P to B and A to T.

Connecting cable:

Recommendation:

Cable length up to 25m, model LiYCY 5x0.75mm²

Cable length up to 50m, model LiYCY 5x1.0mm²

The external diameter of the cable is 6.5 to 11mm

The connection of screen to PE on the supply side only.

¹⁾ Contacts C and F are not allowed to be connected together.

Proportional Directional Valve

Model: 4WRE(E)...2XJ

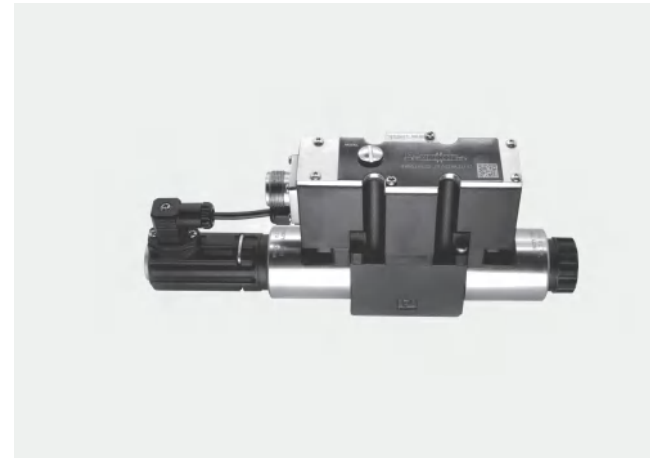

- ◆ Size 6 and 10
- ◆ Maximum working pressure 315 bar
- ◆ Maximum working flow 80 L/min (size 6)
180 L/min (size 10)

Contents

Function description, sectional drawing	02-03
Functional symbols	03
Models and specifications	04
Technical parameters	05
Characteristic curve	06-11
Component size	12-15
Electrical connections	16-17

Features

- proportional directional valve with direct operated proportional solenoid
- For subplate mounting
- Control the direction and flow
- Spring centred control spool
- Internal amplifier, current input A1 or F1, optional
- Operated by proportional solenoids with thread and detachable coil
- Both valves and proportional amplifiers from the same supplier

Function description, sectional drawing

The 4WRE(E) valve is a 4/2-way and 4/3-way proportional directional valve with direct operated and subplate mounting. It is actuated by proportional solenoids with central thread and detachable coil. The control of the solenoids can be achieved through an external amplifier (4WRE) or internal amplifier (4WREE).

Structure:

The valves consist of:

- Valve body with mounting surface (1)
- Control spool (2) with compression springs (3 and 4) and spring seats (X1 and X2)
- Solenoids (5 and 6) with central thread
- Position sensor (7)
- Optional amplifier (8)
- Mechanical zero adjustment (9) accessible by Pg13.5, electrical zero point adjustment (10) accessible by Pg7 for model 4WREE

Operating principle:

- When the solenoids (5 and 6) are de-energized, the compression springs (3 and 4) hold the control spool (2) in the central position between spring seats (X1 and X2)
 - After the proportional solenoid is energized, it will directly push the control spool (2), e.g. energization of solenoid "b" (6):
 - The control spool (2) is pushed to the left in proportion to the electrical input signal
 - At this time, P to A and B to T are connected through the throttle formed by the spool and the valve body with progressive flow characteristics
 - De-energization of solenoid (6)
 - The control spool (2) is pushed back to the center position by the compression spring (3)
- In the de-energized condition, the spool (2) is held in the mechanical central position via the reset springs. There is no related to the hydraulic central position for the spool symbol "V". When the valve control loop is closed, the spool is in the hydraulic central position.

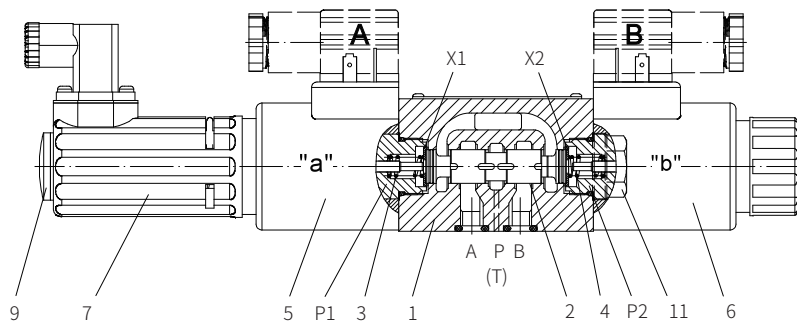

Model 4WRE6...2XJ

Function description, sectional drawing

Two Position Valves:

(Mode I4WRE...A...)

In principle, the function of this valve is similar to the valve with three-position, but it is installed with solenoid "a" only. A plug 8.1 is installed instead of the proportional solenoid "b".

Note for model 4WRE6...-2XJ/...:

It must be avoided to drain all the oil in the return line. If necessary, a back pressure valve is to be installed in the circuit (back pressure about 2 bar).

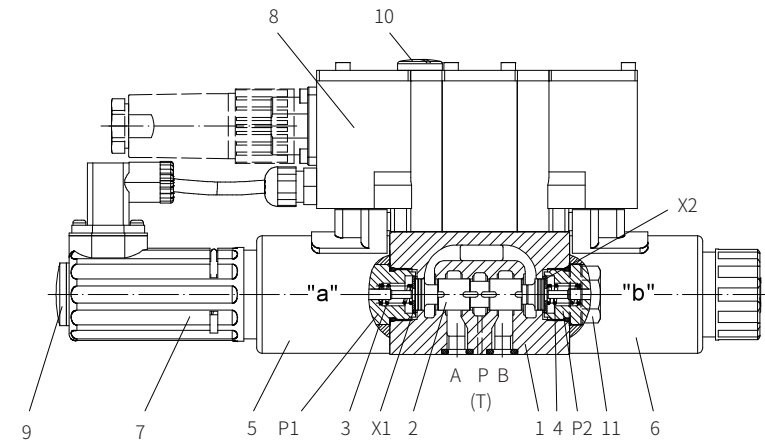

Model 4WREE6...-2XJ/

Functional symbols

Without amplifier

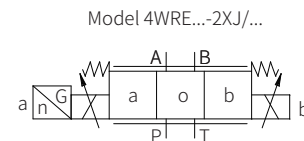

Model 4WRE...A-2XJ/...

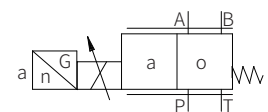

With amplifier

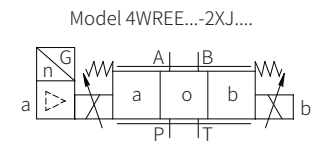

Model 4WREE...A-2XJ/...

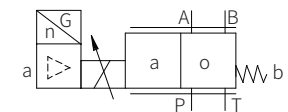

Models and specifications

4WRE

without amplifier =No code
with amplifier =E

size 6 = 6
size 10 = 10

more information in text

sealing material
No code= NBR seals
V= FKM seals
(consult for other seals)

electrical connection for 4WREE
A1= command value input ± 10V
F1= command value input 4 to 20mA
No code= for 4WRE

electrical connections for model 4WRE...
K4= without plug in connector
for model 4WREE...
K31= with plug-in connector

G24= 24V DC

J= Rekith

2X= 20 to 29 series
(20 to 29 series installation and connection size unchanged)

nominal flow rate at valve pressure difference $\Delta P=10\text{bar}$
size 6
08= 8L/min
16= 16L/min
32= 32L/min
size 10
25= 25L/min
50= 50L/min
75= 75L/min

symbols

A B
a 0 b
P T

= E
E1-

= V

= W
W1-

A B
a 0
P T

= EA

= WA

with symbols E1— and W1—:
P→A: $q_{v\max}$ B→T: $q_{v/2}$
P→B: $q_{v/2}$ A→T: $q_{v\max}$
note:
For spools W and WA, when in neutral position, a connection from A to T and B to T with 3% around of the relevant nominal cross-section.

Technical parameters

Overview		
Size		6 10
Installation position		Optional, firstly horizontal
Storage temperature range	°C	-20 to +80
Environment	4WRE °C	-20 to +70
Temperature range	4WREE °C	-20 to +50
Weight	4WRE kg	2.2 6.3
	4WREE kg	2.4 6.5
Hydraulic (measured at pressure P=100bar and using HLP46, $\vartheta_{oil}=40^{\circ}\text{C} \pm 5^{\circ}\text{C}$)		
Maximum working pressure	Oil port A, B, P bar	315
	Oil pot T bar	210
Nominal flow rate $q_{v, \text{nom}}$ at $\Delta P=10\text{bar}$	L/min	8, 16, 32 25, 50, 75
Maximum permissible flow	L/min	80 180
Pressure medium		Mineral oil (HL, HLP) to DIN 515241; Biology can quickly decompose Oil according to VDMA 24568; HETG (Rapeseed oil) ¹⁾ ; HEPG (Polyethyleneglycol) ²⁾ ; HEES (Synthetic Fats) ²⁾
Oil temperature range	°C	-20 to +80 (preferably +40 to +50)
Viscosity range	mm ² /S	20 to 380 (preferably 30 to 46)
Cleanliness of oil		The maximum allowable pollution level of oil is to ISO4406 class 20/18/15
Hysteresis	%	≤0.1
Reversal span	%	≤0.05
Response sensitivity	%	≤0.05
Zero shift upon change of hydraulic oil temperature and working temperature	%/10K	0.15 0.1
The oil must meet the cleanliness degree requested by the components in the hydraulic system. Effective oil filtration can prevent failure and increase the service life of the components.		
Electrical		
Size		6 10
Voltage type		DC
Command value signal	voltage input "A1" V	±10
	current input "F1" mA	4 to 20
Solenoid coil	Cold value at 20°C Ω	2.7 3.7
resistance	Maximum warm value Ω	4.05 5.55
Power rate	%	100
Maximum coil temperature	°C	150
Electrical connection	4WRE	With component plug and plug-in connector to DINEN 175301-803 or ISO4400
	4WREE	With component plug and plug-in connector to DINEN 175201-804
Valve protection to EN60529		IP65, plug installed and locked

Characteristic curve

(Measured when using HLP46, $\vartheta_{oil}=40^{\circ}\text{C} \pm 5^{\circ}\text{C}$)

Pressure-input signal characteristic curve (symbol V), $p_s = 100$ bar

Size 6 and 10

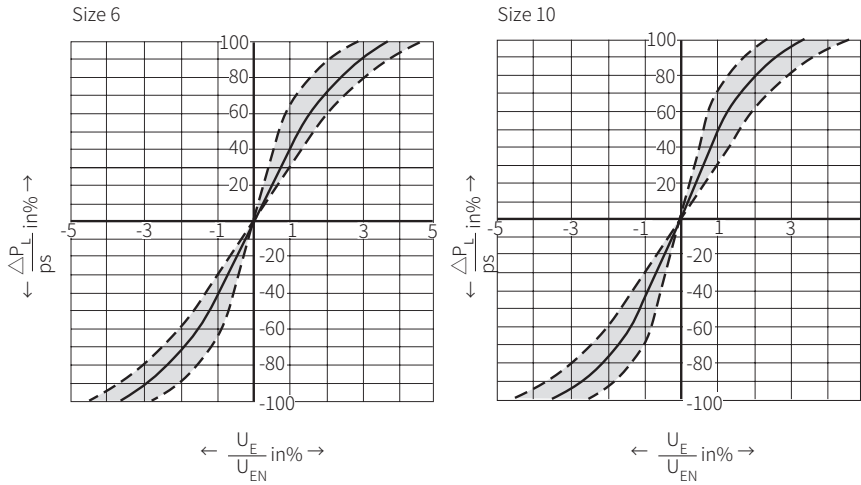

Leakage flow characteristic curve with the spool in the central position

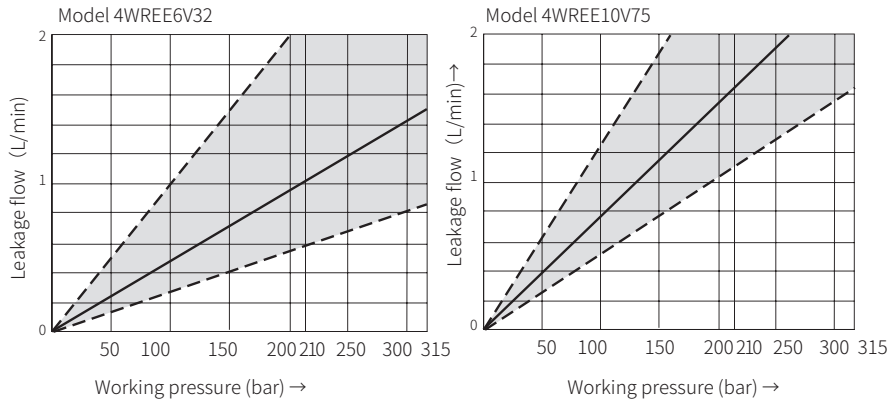

Characteristic curve

(Measured when using HLP46, $\vartheta_{oil}=40^{\circ}\text{C} \pm 5^{\circ}\text{C}$)

The nominal flow rate 8L/min at 10 bar valve pressure difference

Size 6

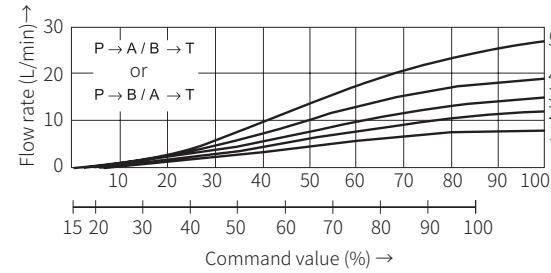

The nominal flow rate 16L/min at 10 bar valve pressure difference

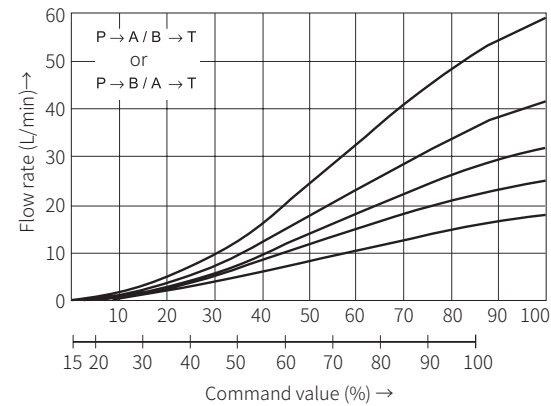

The nominal flow rate 32L/min at 10 bar valve pressure difference

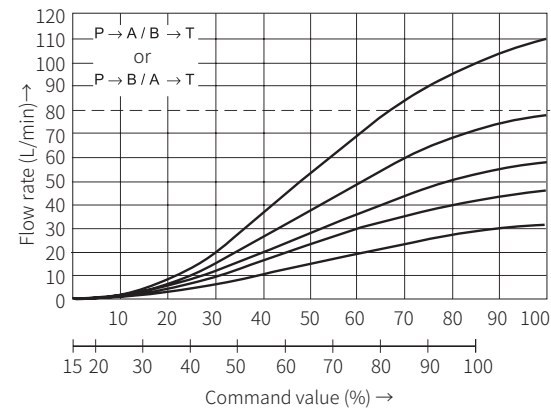

Characteristic curve

(Measured when using HLP46, $\vartheta_{oil}=40^{\circ}\text{C} \pm 5^{\circ}\text{C}$)

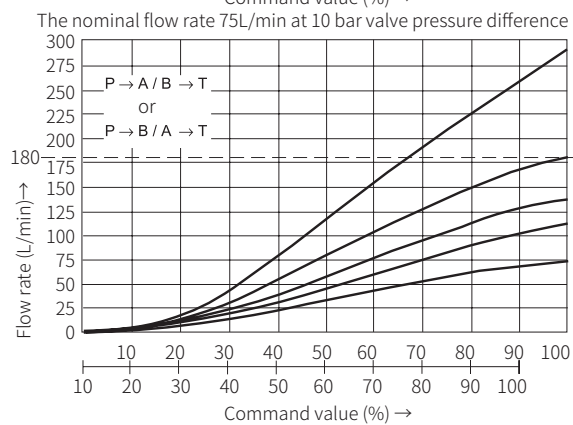
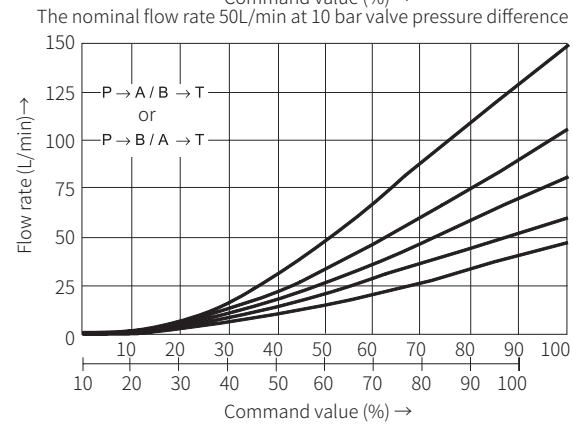
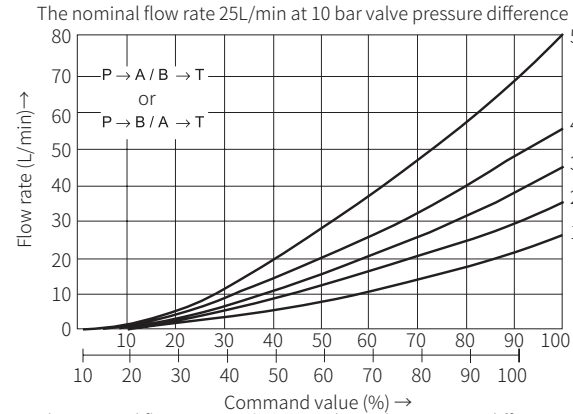

Size 10

- 1 $\Delta P=10$ bar constant
- 2 $\Delta P=20$ bar constant
- 3 $\Delta P=30$ bar constant
- 4 $\Delta P=50$ bar constant
- 5 $\Delta P=100$ bar constant

Symbol "V"
Symbols "E" and "W"

- 1 $\Delta P=10$ bar constant
- 2 $\Delta P=20$ bar constant
- 3 $\Delta P=30$ bar constant
- 4 $\Delta P=50$ bar constant
- 5 $\Delta P=100$ bar constant

Symbol "V"
Symbols "E" and "W"

Maximum permissible flow

- 1 $\Delta P=10$ bar constant
- 2 $\Delta P=20$ bar constant
- 3 $\Delta P=30$ bar constant
- 4 $\Delta P=50$ bar constant
- 5 $\Delta P=100$ bar constant

ΔP =valve pressure difference
(inlet pressure P_p minus load pressure P_L and minus return oil pressure P_r)

Symbol "V"
Symbols "E" and "W"

Characteristic curve

(Measured when using HLP46, $\vartheta_{oil}=40^{\circ}\text{C} \pm 5^{\circ}\text{C}$ and $P_s=10\text{bar}$)

Transition performance of the valve when the input signal is a step signal: model 4WREE Size 6

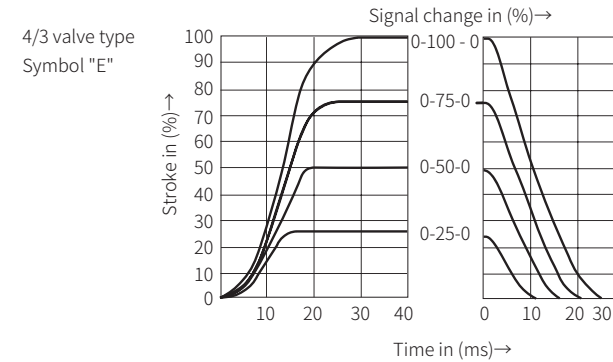

Frequency response: model 4WREE

(Measured when using HLP46, $\vartheta_{oil}=40^{\circ}\text{C} \pm 5^{\circ}\text{C}$ and $P_s=10\text{bar}$)

Size 6

4/3 valve type
Symbol "V"

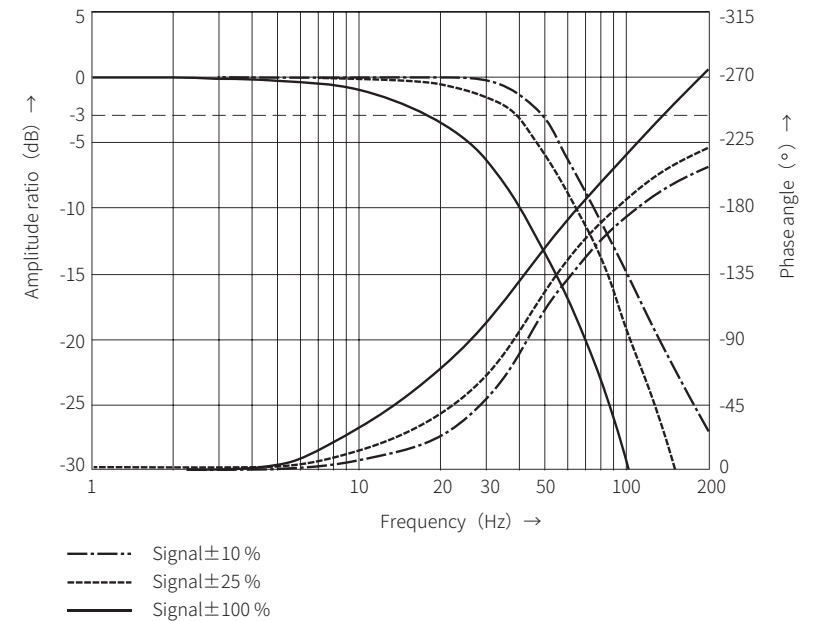

Characteristic curve

(Measured when using HLP46, $\vartheta_{oil}=40^{\circ}\text{C} \pm 5^{\circ}\text{C}$ and $P_s=10\text{bar}$)

Transition performance of the valve when the input signal is a step signal: model 4WREE

Size 10

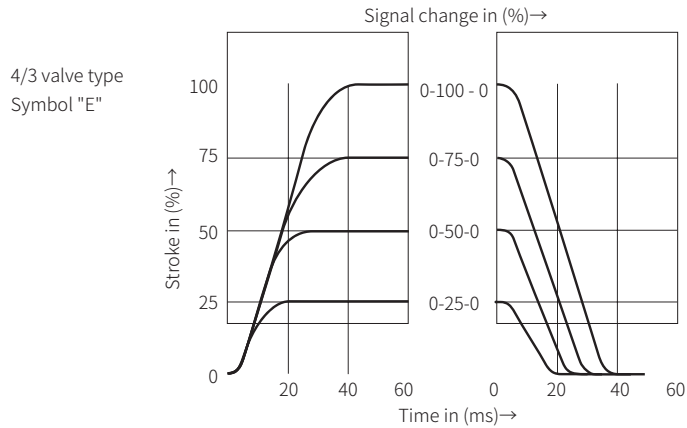

Frequency response: model 4WREE
(Measured when using HLP46, $\vartheta_{oil}=40^{\circ}\text{C} \pm 5^{\circ}\text{C}$ and $P_s=10\text{bar}$)

Size 10

4/3 valve type
Symbol "V"

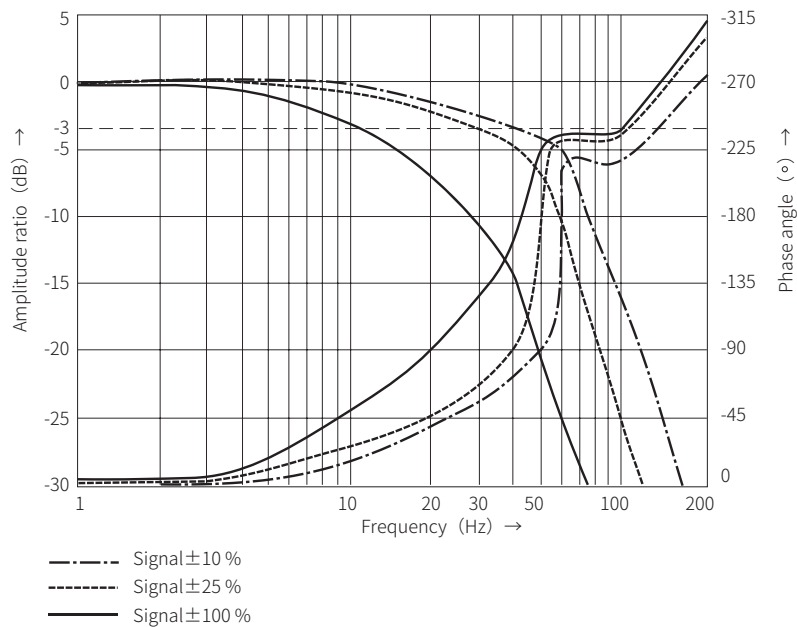

Characteristic curve

Flow: model 4WREE (Measured when using HLP46, $\vartheta_{oil}=40^{\circ}\text{C} \pm 5^{\circ}\text{C}$ and $P_s=10\text{bar}$)

Size 6

The load function with maximum valve opening, nominal flow 8L/min, 16L/min, and 32L/min. symbol "V"

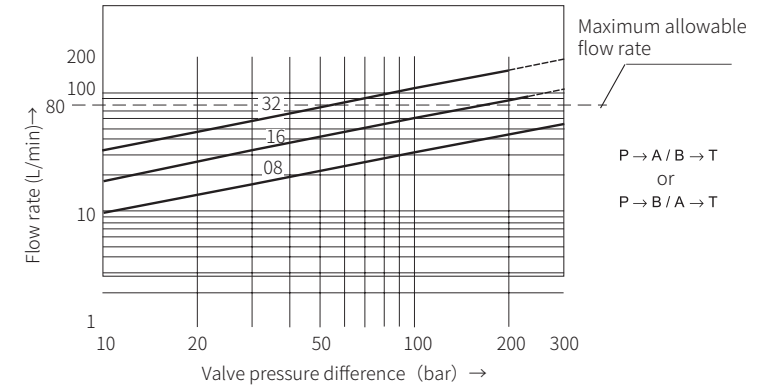

Need to consider the maximum allowable flow rate of 80 L/min!

Flow: model 4WREE (Measured when using HLP46, $\vartheta_{oil}=40^{\circ}\text{C} \pm 5^{\circ}\text{C}$ and $P_s=10\text{bar}$)

Size 10

The load function with maximum valve opening, nominal flow 25L/min, 50L/min, and 75L/min. symbol "V"

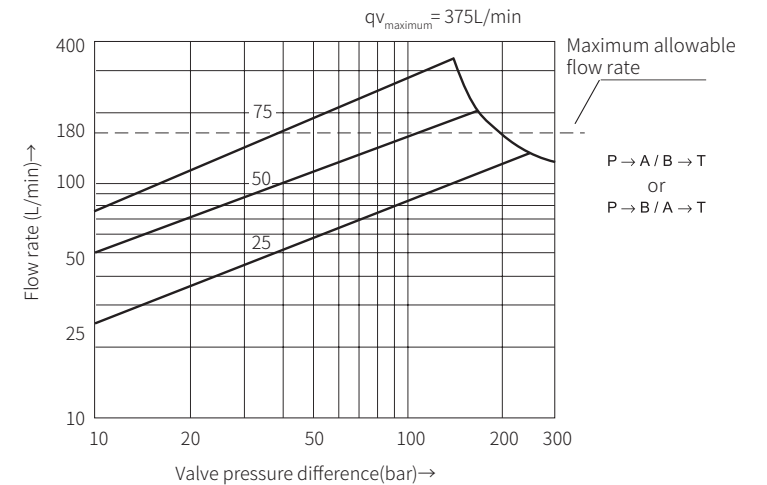

Need to consider the maximum allowable flow rate of 80 L/min!

Component size

Size unit: mm

Model 4WRE6...-2XJ/...

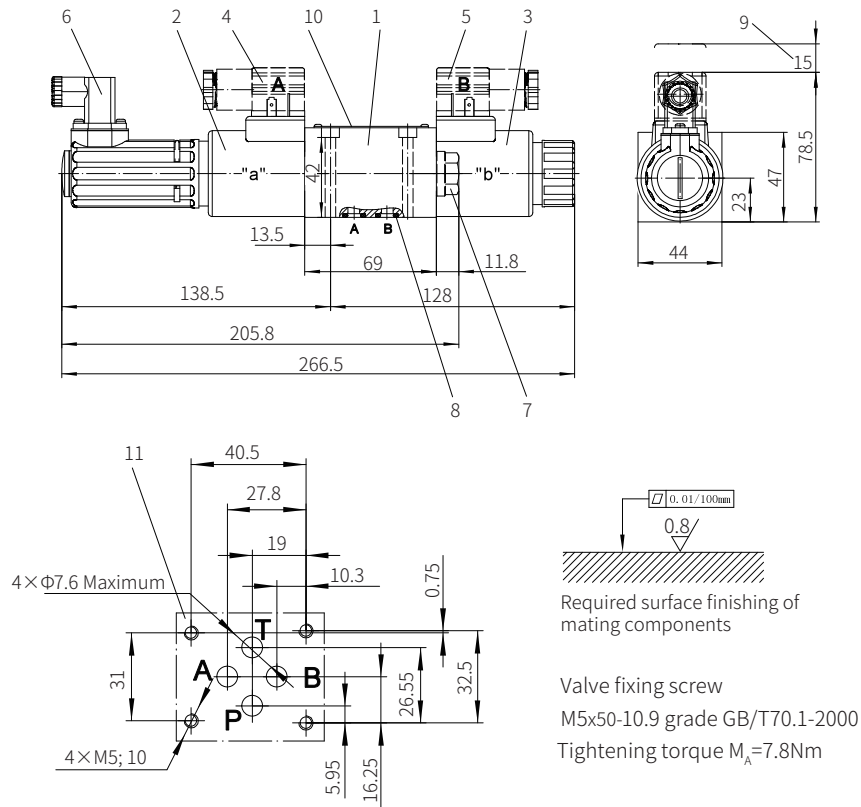

- 1 Valve body
- 2 Proportional solenoid "a" with inductive position sensor
- 3 Proportional solenoid "b"
- 4 Grey plug "A"
- 5 Black plug "B"
- 6 Inductive position sensor plug
- 7 Plug for valve with one solenoid (two-position valve, symbol EA or WA)
- 8 O-ring 9.25x1.78 (for oil port P, A, B, T)
- 9 Space required to remove the plug
- 10 Name plate
- 11 Valve connection surface

Component size

Size unit: mm

Model 4WREE6...-2XJ/...

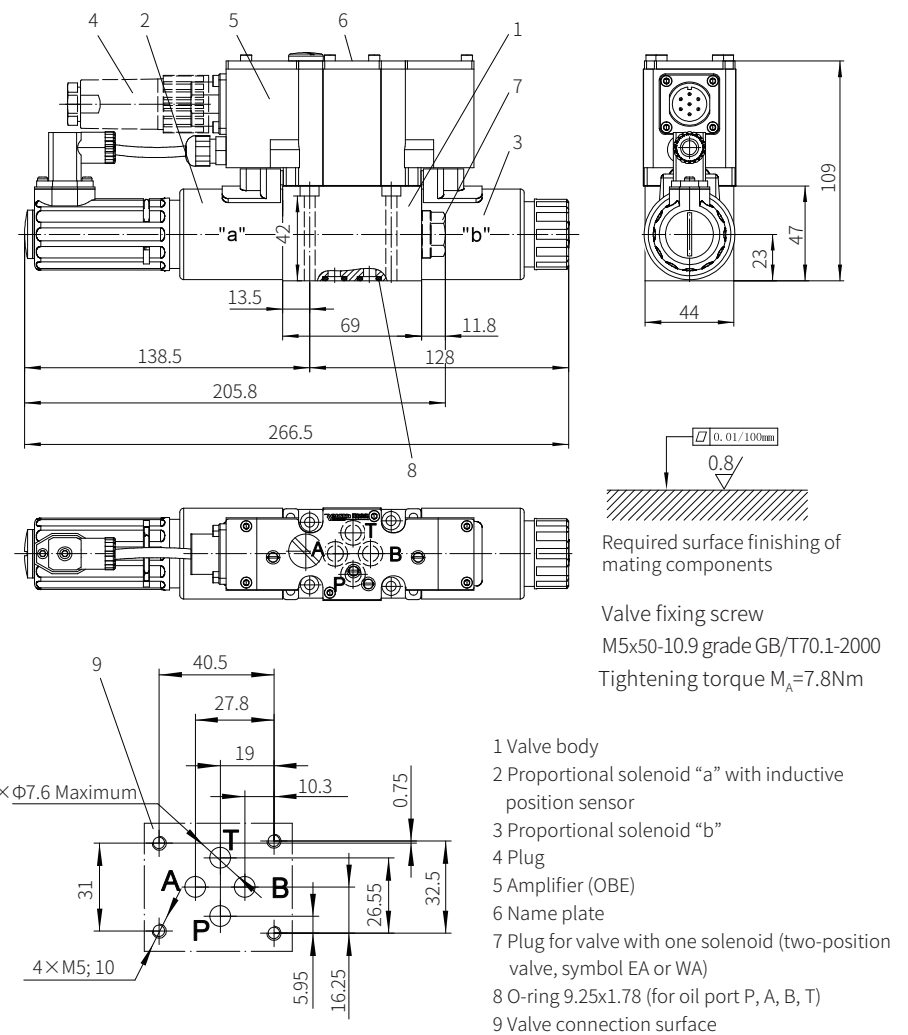

Component size

Size unit: mm

Model 4WRE10...-2XJ/...

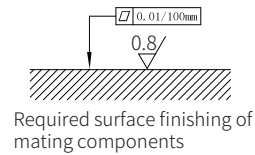
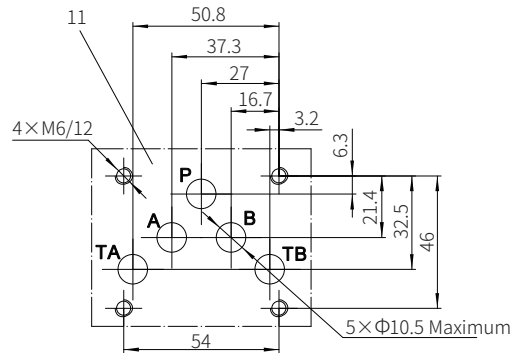
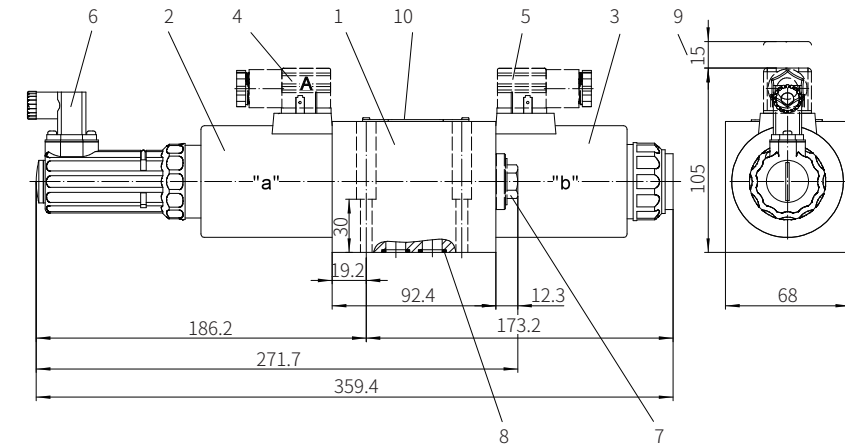

Valve fixing screw
M6x40-10.9 grade GB/T70.1-2000
Tightening torque $M_A=13.7\text{Nm}$

- 1 Valve body
- 2 Proportional solenoid "a" with inductive position sensor
- 3 Proportional solenoid "b"
- 4 Grey plug "A"
- 5 Black plug "B"
- 6 Inductive position sensor plug
- 7 Plug for valve with one solenoid (two-position valve, symbol EA or WA)
- 8 O-ring 12x2 (for oil port P, A, B, T)
- 9 Space required to remove the plug
- 10 Name plate
- 11 Valve connection surface

Component size

Size unit: mm

Model 4WREE10...-2XJ/...

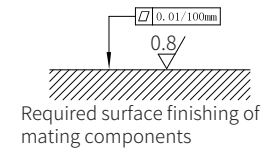
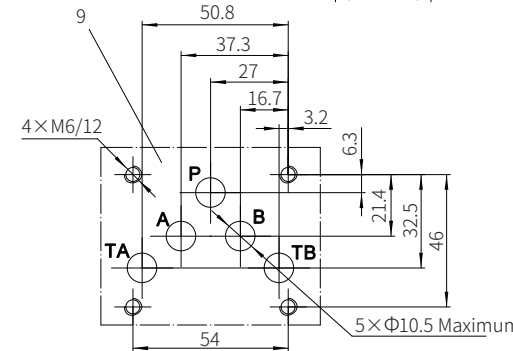
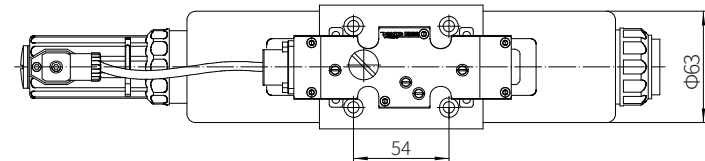
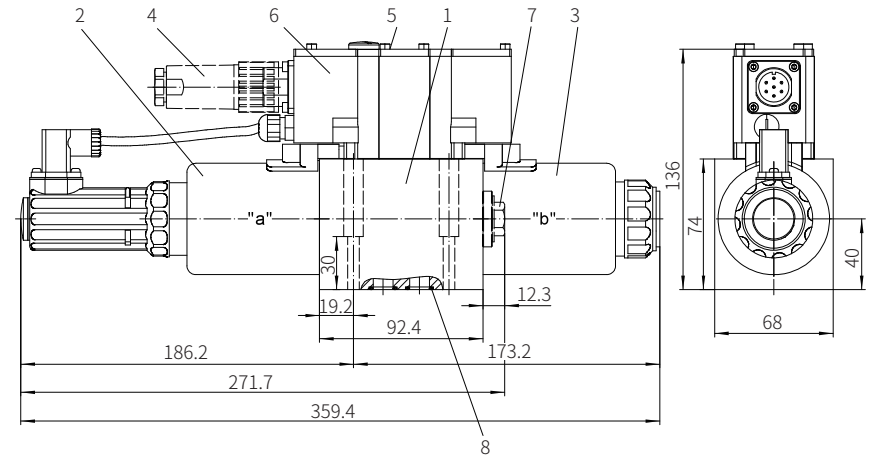

Valve fixing screw
M6x40-10.9 grade GB/T70.1-2000
Tightening torque $M_A=13.7\text{Nm}$

- 1 Valve body
- 2 Proportional solenoid "a" with inductive position sensor
- 3 Proportional solenoid "b"
- 4 Plug
- 5 Name plate
- 6 Amplifier
- 7 Plug for valve with one solenoid (two-position valve, symbol EA or WA)
- 8 O-ring 12x2 (for oil port P, A, B, T)
- 9 Valve connection surface

Electrical connections

Model 4WRE...2XJ/...(Without built-in amplifier)

Component plug connection form

The plug-in connector to DIN175301-803 or ISO4400

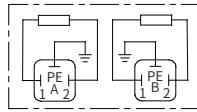

Component plug connection form

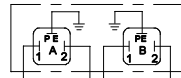

Inductive position sensor

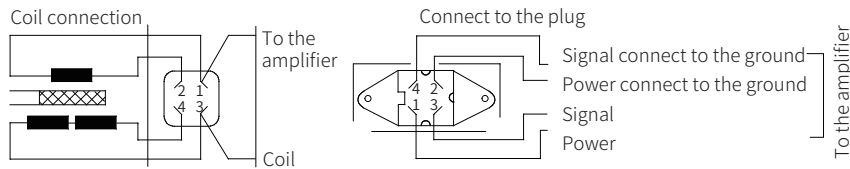

Plug connector 4-pin Pg7-G4W1F

Connecting cable:

Recommendation:

Cable length up to 50m, model LiYCY 4x0.25mm²

The connection of screen to PE on the supply side only.

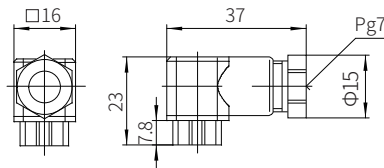

Model 4WREE...2XJ/...(With built-in amplifier)

The plug-in connector to DINEN 175201-804

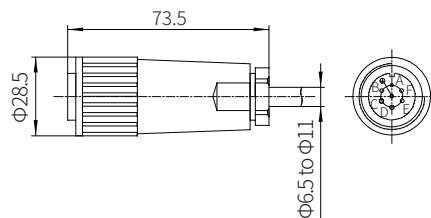

Electrical connections

Model 4WREE...(With built-in amplifier)

Plug allocation

Terminal identification	Contact	A1 signal	F1 signal
Supply voltage	A	24VDC (u (t) =19.4 to 35V), I _{max} =2A	
	B	0V	
Reference potential (actual value)	C	Reference contact F, R _e >50K Ω	Reference contact F, R _e >10K Ω
Differential amplifier input	D	±10V, R _e >50K Ω	4 to 20mA, R _e >100Ω
	E	Reference potential command value	
Measurement output (actual value)	F	Actual value ± 10V (limit load 5mA)	Actual value 4 to 20mA (maximum load resistance 300 Ω)
	PE	Connected with the valve body and cooling element	

Command value:

A positive command value 0 to +10V (or 12 to 20mA) at D and E causes a flow from P to A and B to T.

A negative command value 0 to -10V (or 12 to 4mA) at D and E causes a flow from P to B and A to T.

For valves only with one solenoid in side "A" (symbols EA and WA), a positive command value at D and E causes a flow from P to B and A to T.

Actual value:

A positive actual value 0 to +10V (or 12 to 20mA) at F and C causes a flow from P to A and B to T.

A negative actual value 0 to -10V (or 4 to 12mA) at F and C causes a flow from P to B and A to T.

For valves only with one solenoid in side "A" (symbols EA and WA), a positive actual value at F and C causes a flow from P to B and A to T.

Connecting cables:

Recommended:

Cable length up to 25m, model LiYCY 5x0.75mm²

Cable length up to 50m, model LiYCY 5x1.0mm²

The external diameter of the cable is 6.5 to 11mm

The connection of screen to PE on the supply side only.