

## Proportional Directional Valve

Model: 4WRPEH6...2XJ



- ◆ Size 6
- ◆ Maximum working pressure 315 bar
- ◆ Maximum working flow 40 L/min

### Contents

Function description, sectional drawing	02
Models and specifications	03
Functional symbols	03
Technical parameters	04
Electrical connections	05-07
Characteristic curve	08-09
Component size	10

### Features

- Direct operated servo solenoid valve with control piston and valve sleeve, with servo performance
- Operated on one side, 4/4-fail-safe position in switched-off condition
- Control solenoid with built-in position feedback and integrated amplifier board (OBE), calibrated in the factory
- Electrical connection 6P+PE signal input differential amplifier with interface A1 ( $\pm 10V$ ) or interface F1 (4... 20mA) (RS200  $\Omega$ )
- Electro-hydraulic controllers for production and testing systems
- Subplate mounting

Any part of this brochure can not be reproduced, edited, copied and disseminated electronically in any way without authorization of Jiayite Hydraulics company. As the product is in constant development and innovation, the information in this brochure is not specific to the special conditions or applicability of a specific industry, thus Jiayite Hydraulics company is not responsible for any incomplete or inaccurate description generated.



**Function description, sectional drawing**

The 4WRPEH valve is high-performance servo proportional valve with zero cover structure on the valve spool and valve sleeve, and LVDT position transducer, it can regulate the directional and flow steplessly according to the input electrical signals.

The valve mainly consists of valve body (1), valve spool (2), valve sleeve (3), control solenoid with position transducer (4), and optionally integrated amplifier (5).

The valve drives the movement of the spool on one side through the proportional solenoid. The specified command value is compared with the actual position value in the integrated electronics (OBE). In case of control deviation, the stroke solenoid is activated, which adjusts the control spool against the spring due to the changed solenoid force. The stroke/control spool cross-section is regulated proportionally to the command value. When the command value presetting of 0V, the electronics adjusts the control spool against the spring to the central position. In deactivated condition, the spring is untensioned to a maximum and the valve is in fail-safe position.

When the solenoid switched off, the valve is moved to fail-safe position. And after powered on, the valve spool is pushed from the rest position to the required position according to the size of the input electrical signal to achieve free flow of oil from P to A and B to T, or P to B and A to T.

The 7-pin connector (6) is used for connecting power, analog signal input, and detection signals.

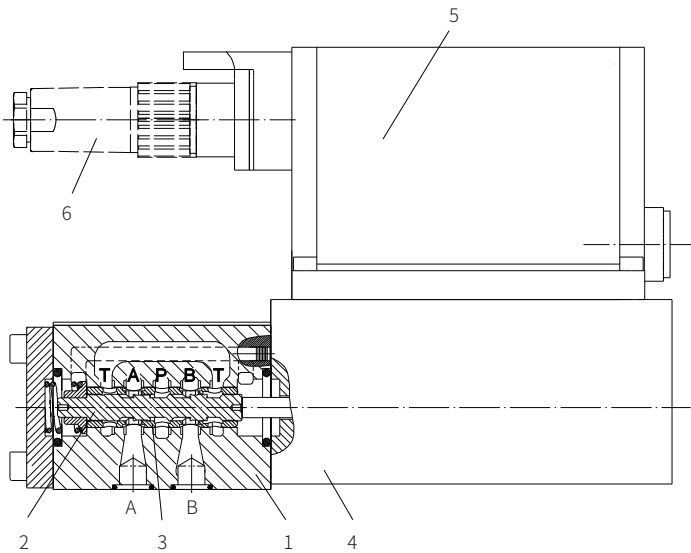

Model 4WRPEH6...-2XJ/

04

**Models and specifications**



with integrated electronics =E

control piston valve sleeve =H

size 6 =6

symbols

four position four-way type

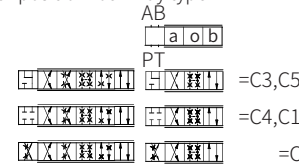

with symbols C5 and C1<sup>3)</sup> :

P→A:  $q_v$  B→T:  $q_v/2$

P→B:  $q_v/2$  A→T:  $q_v$

Installation side of the inductive position transducer



1) only related to the flow characteristic "p"

2) Inflection 60% is for nominal flow rates of "15" and "25" with size 6, otherwise the inflection is 40%

3)  $q_{v2:1}$  is only used for nominal flow rate=40L/min

more information in text

sealing material  
No code= NBR seals  
V= FKM seals  
(consult for other seals)

electrical connection  
A1= command value input  $\pm 10V$   
F1= command value input 4 to 20 mA

electrical connections without plug-in connector with component plug to DIN 43563-AM6

power supply to amplifier +24V DC

G24=

J= Rekith

2X= 20 to 29 series  
(20 to 29 series installation and connection size unchanged)

L= linear flow characteristic  
P= inflected characteristic curve<sup>2)</sup>

nominal flow rate at 70 bar differential pressure (35 bar/throttle edge)

size 6

02=2 L/min 12=12 L/min 24=24 L/min 40<sup>3)</sup>= 40 L/min

04=4 L/min 15<sup>1)</sup>=15 L/min 25<sup>1)</sup>= 25 L/min

04

**Functional symbols**

	Linear	P: Inflection 60% ( $q_v=15, 25$ L/min)	P: Inflection 40% ( $q_v=40$ L/min)
	C3, C5	C3, C5, C4, C1	C3, C5, C4, C1
	C4, C1	C3, C5, C4, C1	C3, C5, C4, C1
	C	C3, C5, C4, C1	C3, C5, C4, C1

## Technical parameters

Overview		
Structure	Direct operated spool valve with steel sleeve	
Actuation	Proportional solenoid valve with position controller, OBE	
Installation type	subplate mounting, porting pattern to ISO 4401-03-02-05	
Installation position	Optional	
Environment temperature range	°C -20 ~ +50	
weight	kg 2.75	
Vibration resistance (testing conditions)	Maximum 25g, space vibrating test in all directions (24h)	
Hydraulic (Measured when using HLP46, $\nu_{oil} = 40^{\circ}\text{C} \pm 5^{\circ}\text{C}$ )		
Fluid	Oil according to DIN 51524. For other oils, please consult our company	
Viscosity range	Recommended value mm <sup>2</sup> /s	20...100
	Maximum allowable value mm <sup>2</sup> /s	10...800
Oil temperature range	°C	-20 to +70
The maximum allowable pollution level of oil to ISO 4406 (c)		Class 18/16/13 <sup>1)</sup>
Nominal flow rate ( $\Delta p=35$ bar per throttle edge)	L/min	2    4    12    24    40
Maximum working pressure	bar	Port A, B, P: 315 Port T: 250
Leakage flow at 100 bar	Linear cm <sup>3</sup> /min	<150    <180    <300    <500    <900
	Nonlinear cm <sup>3</sup> /min	—    —    —    <300    <450
Static/dynamic		
Hysteresis	%	≤0.2
Response time for signal changes 0-100%	ms	10
Zero drift		At $\Delta T=40^{\circ}\text{C}$ , zero drift <1%
Zero position adjustment		Factory setting $\pm 1\%$
Electrical, amplifier integrated in valve		
Power on rate	%	100ED
Protection grade		IP65 (plug installed)
Connection		Plug-in connector 6P+PE, DIN 43563
Supply voltage		24V DC <sub>nom</sub>
Terminal A		Min. 21VDC/max. 40VDC
Terminal B		0V (ripple max.2)
External fuse	A <sub>F</sub>	2.5
Input, version "A1"		Analog differential signal input, Ri=100k $\Omega$
Terminal D(U <sub>D</sub> )		0...±10V
Terminal E		0V
Input, version "F1"		Load, Rsh=200 $\Omega$
Terminal D(I <sub>D,E</sub> )		4...12...20mA
Terminal E(I <sub>D,E</sub> )		Current loop I <sub>D,E</sub> feedback
Test signal, version "A1"		LVDT
Terminal F(U <sub>I,est</sub> )		0...±10V
Terminal C		Reference 0V
Test signal, version "F1"		LVDT signal 4... (12).. 20 mA
Terminal F(I <sub>F,C</sub> )		200...500 $\Omega$
Terminal C(I <sub>F,C</sub> )		4... (12)... 20 mA (output current) Current loop I <sub>F,C</sub> feedback
Adjustment		Calibrate at the factory and see the characteristic curve of the valve

The oil must meet the cleanliness degree requested by the components in the hydraulic system. Effective oil filtration can prevent failure and increase the service life of the components.

## Electrical connections

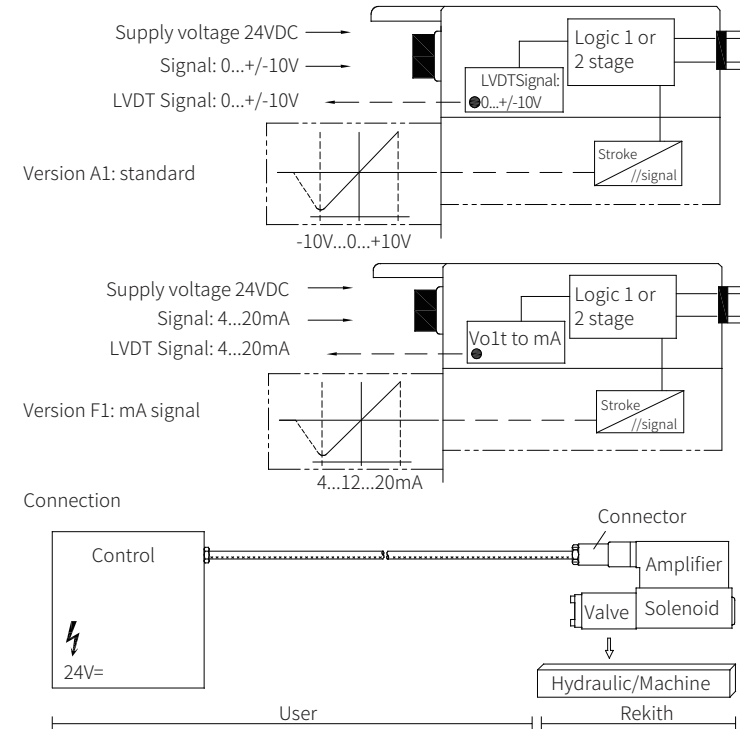

Technical data for the cable:

- Version: - Multi-core wire
  - Litz wire structure, extra fine wire according to VDE 0295, class 6
  - Protective earthing conductor, green-yellow
- Wire number: - determined by the valve model, plug model, and signal arrangement
- Line  $\varnothing$ : - 0.75 mm<sup>2</sup> to 20m of length
  - 1.0 mm<sup>2</sup> to 40m of length
- Outer  $\varnothing$ : - 9.4...11.8 mm
  - 12.7...13.5mm

Note:

Supply voltage 24 V DC<sub>nom</sub> if the value falls below 18V, an internal fast switch-off is effected which can be compared with "Release OFF" Additionally for version F1:

- I<sub>D,E</sub> ≥ 3mA - valve is active
- I<sub>D,E</sub> ≤ 2mA - valve is deactivated

Electric signals taken out via control electronics (e.g. actual value) may not be used for the switch-off of safety-relevant machine functions. (See the European standard "Safety requirements for fluid power systems and their components - Hydraulics", EN 982.)

Electrical connections

Integrated amplifier (OBE)

Circuit block diagram/wiring diagram

Model A1:  $U_{D,E} 0... \pm 10V$

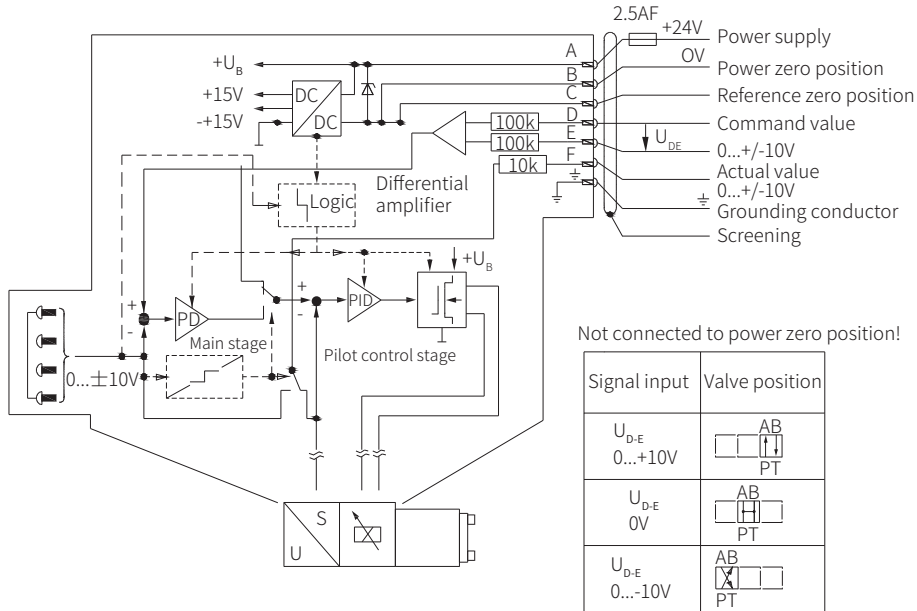

Terminal identification 6P+PE

Model A1:  $U_{D,E} \pm 10V$  ( $R_i=100K\Omega$ )

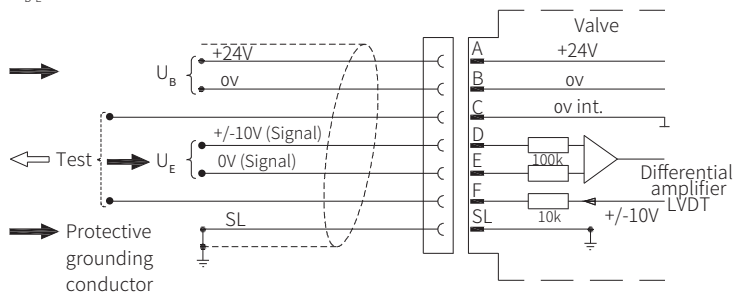

Electrical connections

Integrated amplifier (OBE)

Circuit block diagram/wiring diagram

Model F1:  $I_{D,E} 4...20mA$

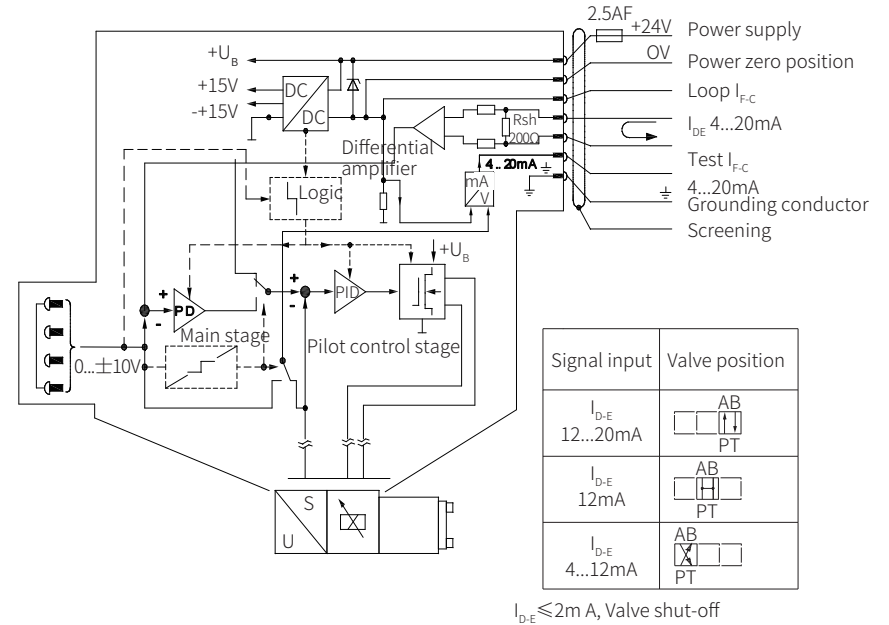

Terminal identification 6P+PE

Model F1:  $I_{D,E} 4...20mA$  ( $R_{sh}=200\Omega$ )

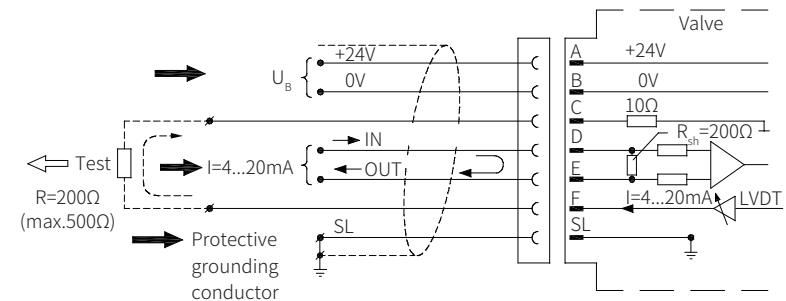

Characteristic curve

(Measured when using HLP46,  $\vartheta_{oil}=40^{\circ}\text{C} \pm 5^{\circ}\text{C}$ )

Flow/signal function  $q_v=f(U_{D,E}), q_v=f(I_{D,E})$

Linear characteristic curve (version "L")

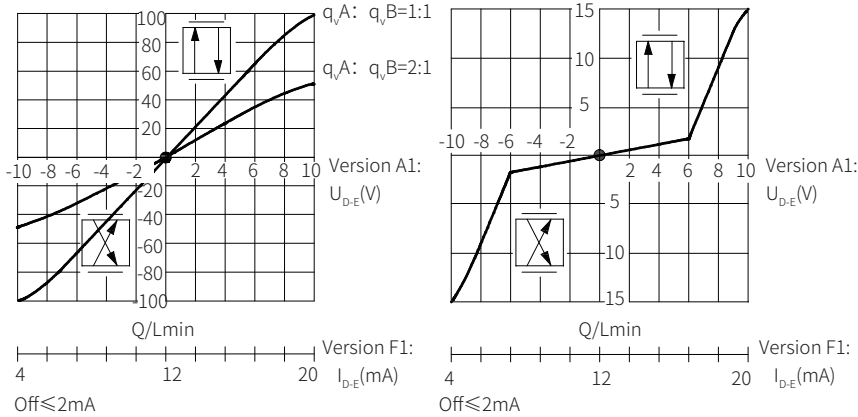

P: Inflection at 40%

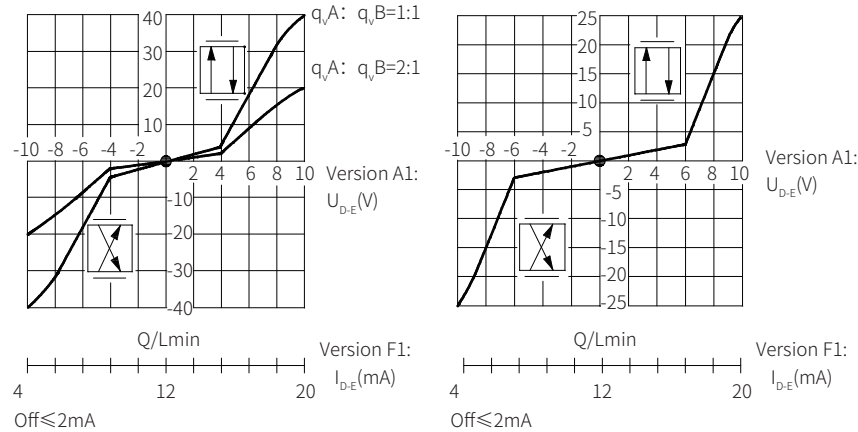

P: Inflection at 60%

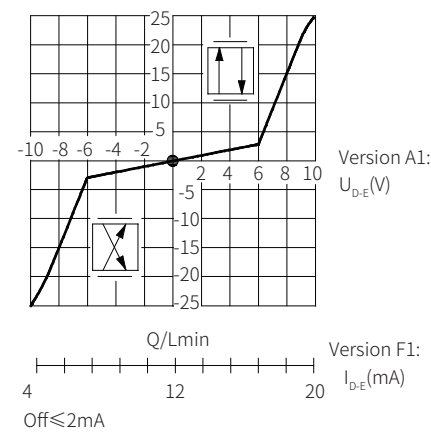

Characteristic curve

Pressure gain curve

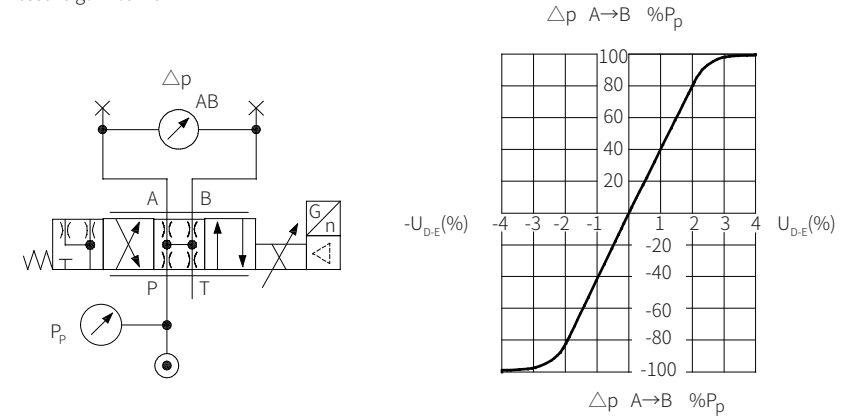

Bode diagram

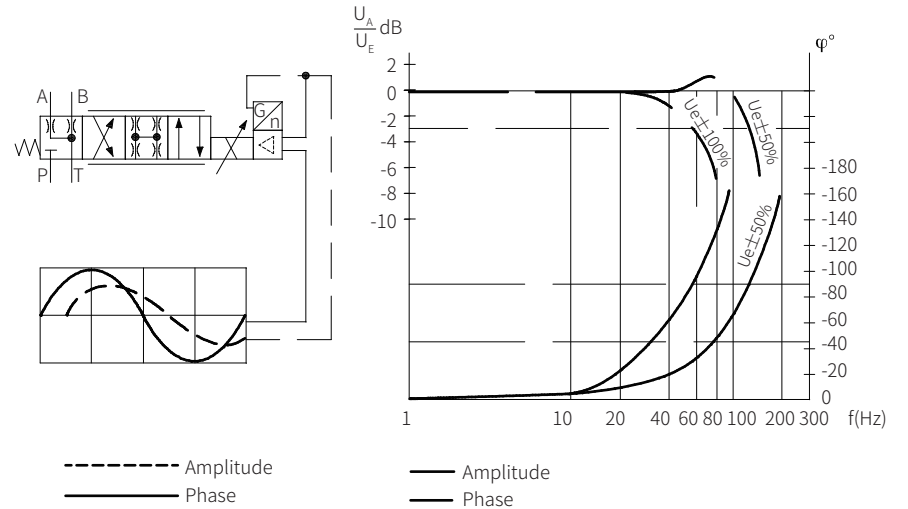

## Component size

Size unit: mm

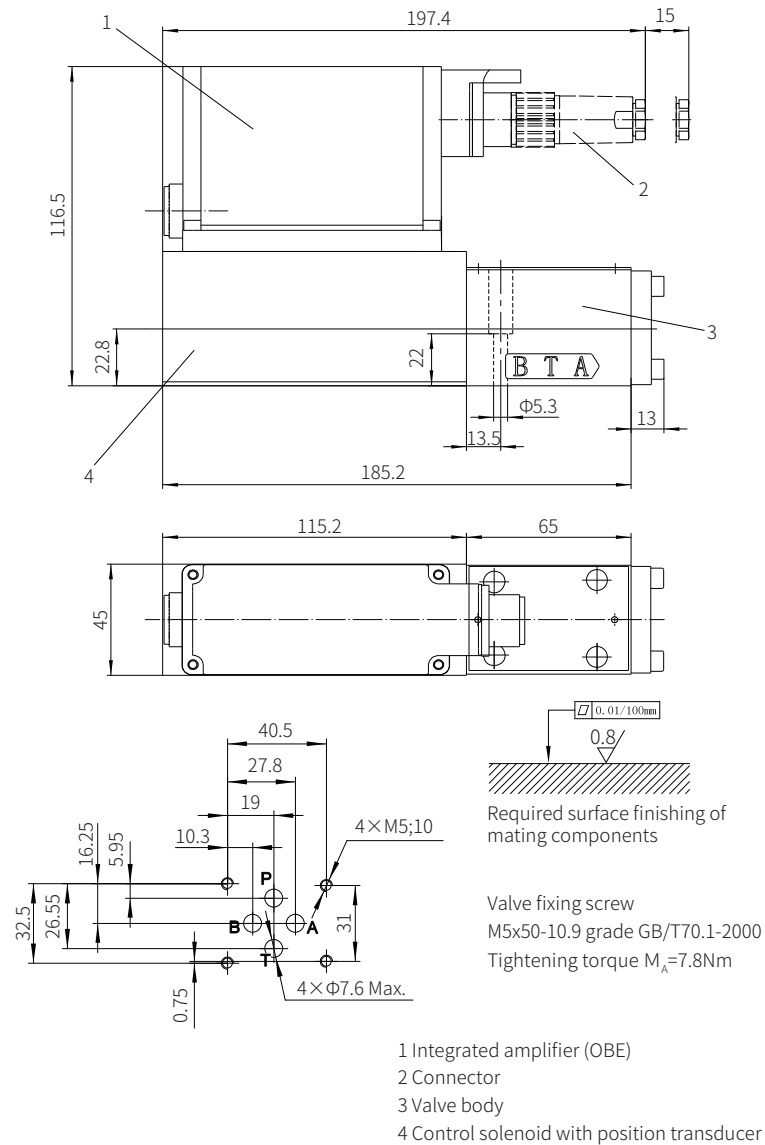

## Proportional Directional Valve

Model: 4WRPEH10...2XJ



- ◆ Size 10
- ◆ Maximum working pressure 315 bar
- ◆ Maximum working flow 100 L/min

## Contents

Function description, sectional drawing	02
Models and specifications	03
Functional symbols	03
Technical parameters	04
Electrical connections	05-07
Characteristic curve	08-09
Component size	10

## Features

- Direct operated servo solenoid valve with control piston and valve sleeve, with servo performance
- Operated on one side, 4/4-fail-safe position in switched-off condition
- Control solenoid with built-in position feedback and integrated amplifier board (OBE), calibrated in the factory
- Electrical connection 6P+PE signal input differential amplifier with interface A1 ( $\pm 10\text{V}$ ) or interface F1 (4... 20mA) (RS200  $\Omega$ )
- Electro-hydraulic controllers for production and testing systems
- Subplate mounting