

Pilot Operated Unloading Pressure Relief Valve

Model: DA/DAW...5XJ



- ◆ Size 10, 25, 32
- ◆ Maximum working pressure 315 bar
- ◆ Maximum flow rate 240 L/min

Contents

Function description, sectional drawing	02-03
Functional symbols	03
Models and specifications	04
Technical parameters	05
Characteristic curve	06
Component size	07-09
Application example	10

Features

- For subplate mounting
- For manifolds mounting
- 4 adjusting elements
 - Rotary knob
 - Adjusting screw with protective cap
 - Lockable rotary knob with scale
 - Rotary knob with scale
- 4 pressure ranges
- Solenoid operated unloading by a built-on directional valve

Any part of this brochure can not be reproduced, edited, copied and disseminated electronically in any way without authorization of Jiayite Hydraulics company. As the product is in constant development and innovation, the information in this brochure is not specific to the special conditions or applicability of a specific industry, thus Jiayite Hydraulics company is not responsible for any incomplete or inaccurate description generated.



Function description, sectional drawing

The DA/DAW pressure control valve is pilot operated pressure shut-off valve. It is used to switch the pump flow to pressureless bypass when the accumulator loading pressure is reached. The other applications of the valve is in high/low pressure pump system. In this application, the low pressure pump is switched to pressureless bypass when the pressure reaches the high pressure setting value.

The valve is composed of main valve (1) with main spool assembly (3), pilot valve (2) with pressure adjusting element and check valve (4). For size 10 valve, the check valve (4.1) is installed in main valve (1). For size 25 and 32, the check valve (4.2) is built into a separate subplate installed under the main valve (1).

Pressure shut-off valve model DA

Diverting the pump flow from P to A - P to T

The pump supply oil for hydraulic system (P to A) via check valve (4.1). The pressure in port A acts on pilot valve spool (6) via control line (5). At same time, pressure in port P passes to the spring chamber of main spool (3) and conical spool (9) of pilot valve (2) via orifices (7) and (8). The conical spool lifts its valve seat against the spring force (10) when the setting cut-off pressure of the hydraulic system is reached. The fluid flows into spring chamber (11) via orifices (7) and (8), or the fluid returns to tank external via control line (12) in model DA...5XJ...Y.

Due to orifices (7) and (8), there is pressure drop in the main spool (3). The main spool (3) lifts off its seat and opens the connection from P to T. And the check valve (4) closes the connection from A to P. Now the poppet valve (9) is kept opening by the system pressure via pilot valve spool (6).

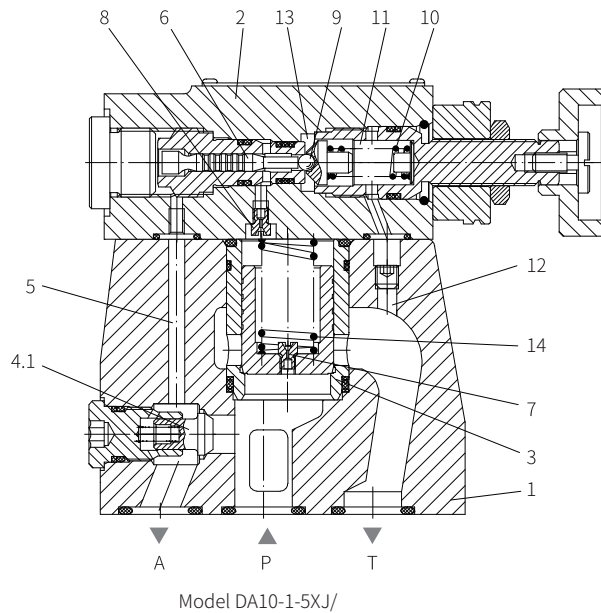

Function description, sectional drawing

Diverting the pump flow from P to T - P to A

The area of the pilot spool (6) is 10% or 17% greater than the effective area of the conical spool (9), thus the effective force on the pilot valve spool (6) is 10% or 17% greater than the effective force on the conical spool (9). When the actuator pressure drop to equal the cut-off pressure of the valve that corresponds to the switching pressure differential, the spring (10) pushes the poppet valve (9) on to its seat. The pressure is built up on the spring loaded side of the main spool (3). In conjunction with spring (14), the main spool (3) is closed and the connection from port P to T is isolated. The pump flow passes again via the check valve (4) into the hydraulic system (P to A).

Pressure shut-off valve model DAW

The function of this valve is basically the same as the DA valve. But a solenoid directional valve (15) can switch the setting shut-off pressure of the pilot valve (2) either from P to A or from P to T.

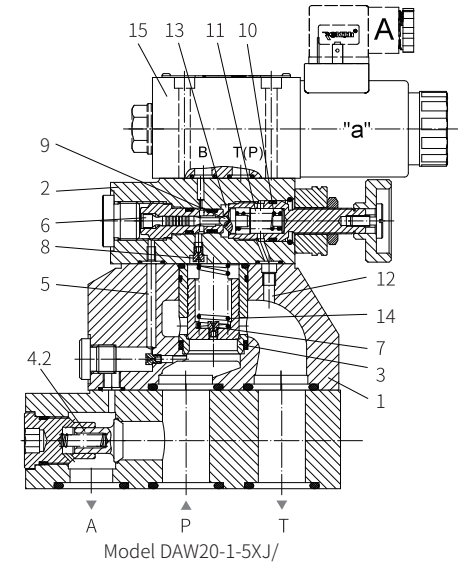

Functional symbols

Model DA...5XJ/...

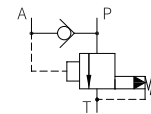

Model DA...-5XJ/...Y...

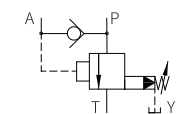

Model DAW...-5XJ/...

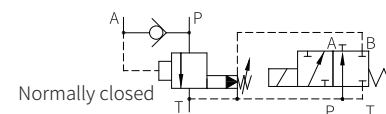

Model DAW...A...-5XJ/...Y...

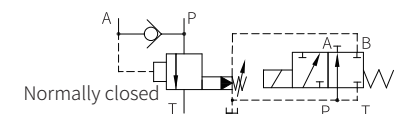

Model DAW...B...-5XJ/...



Model DAW...B...-5XJ/...Y...



Models and specifications

DA		5X		J		*	
without directional valve	=No code						more information in text
with directional valve=W							sealing material
							No code= NBR seals
							V= FKM seals
							(consult for other seals)
pilot valve without main spool insert (no mark for size)	=No code						electrical connection
pilot valve with main spool insert (mark for size 30)	=C						Z4= standard plug
							Z5L= large right angle lamp plug
size 10	=10						No code= no manual emergency operation
size 25	=20						N9= with hidden manual emergency operation
size 32	=30						G24= DC24V
							W220-50= AC 220V50/60Hz
	normally closed=A						No code= without directional valve
	normally open =B						C= with directional valve
adjusting element rotary knob	=1						No code= pilot control oil drain internal
adjusting screw with protective cap	=2						Y= pilot control oil drain external
lockable rotary knob with scale	=3						switching pressure differential (P-A)
rotary knob with scale	=7						10= On average 10 %
							17= On average 17 %
50 to 59 series (50 to 59 series installation and connection size unchanged)	=5X						pressure range
Rekith	=J						50= pressure setting up to 50 bar
							100= pressure setting up to 100 bar
							200= pressure setting up to 200 bar
							315= pressure setting up to 315 bar

Technical parameters

Size			Size 10	Size 25	Size 32
Weight	DA	kg	3.8	7.7	13.5
	DAW	kg	5.3	9.2	15
	DAC	kg	1.2		
	DAWC	kg	2.4		
	DAC30	kg	1.5		
	DAWC30	kg	2.7		
Installation position			Optional		
Hydraulic					
Maximum working pressure	Oil port P	bar	315		
	Oil port A	bar	315(after switching from P to T)		
Hydraulic oil			Mineral oil (HL, HLP) ¹⁾ in accordance with DIN 51524; Fast living organisms degraded oil according to VDMA 24568; HETG (Rapeseed oil) ¹⁾ ; HEPG(Polyethyleneglycol) ²⁾ ; HEES (Synthetic Fats) ²⁾		
Oil temperature range		°C	-30 to +80 (NBR seal)		
		°C	-20 to +80 (FKM seal)		
Viscosity range			mm ² /s 10 to 800		
Maximum flow	Type 10%	L/min	40	80	120
	Type 17%	L/min	60	120	240
Cleanliness of oil			The maximum allowable pollution level of oil is ISO4406 Class 20/18/15		
Maximum setting pressure			bar 50; 100; 200; 315		

1) For NBR seal and FKM seal.

2) Only for FKM seal.

3) The oil must meet the cleanliness degree requested by the components in the hydraulic system.

Effective oil filtration can prevent failure and increase the service life of the components.

Characteristic curve

(Measured when using HLP46, $\vartheta_{oil}=40^{\circ}\text{C} \pm 5^{\circ}\text{C}$)

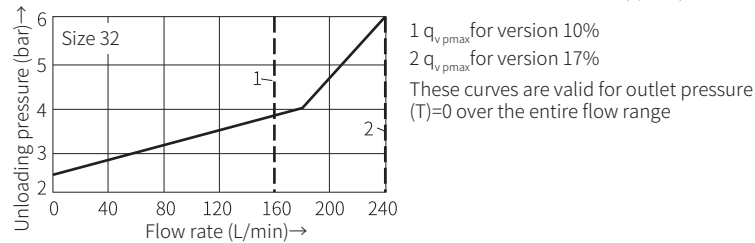
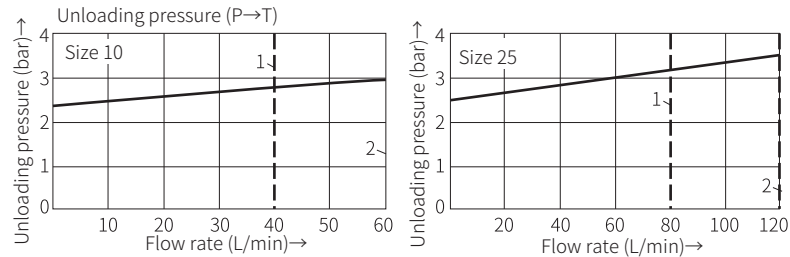

Switching differential pressure in relation to shut-off pressure (P→A)

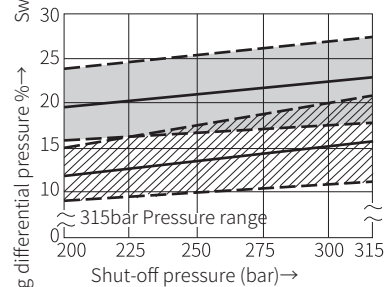
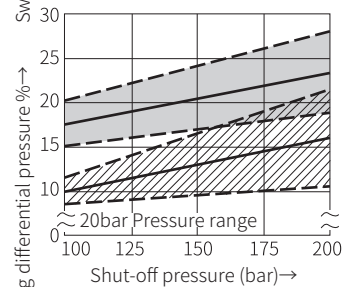
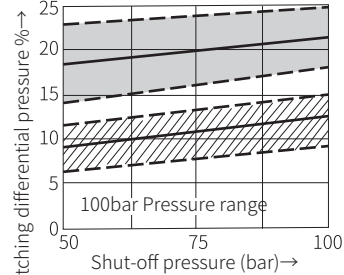
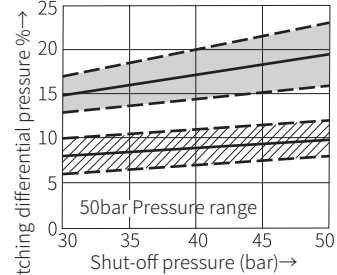

=Scatter range for version "10"

=Scatter range for version "17"

Component size

Size unit: mm

Model DA10/DAW10...-5XJ/...

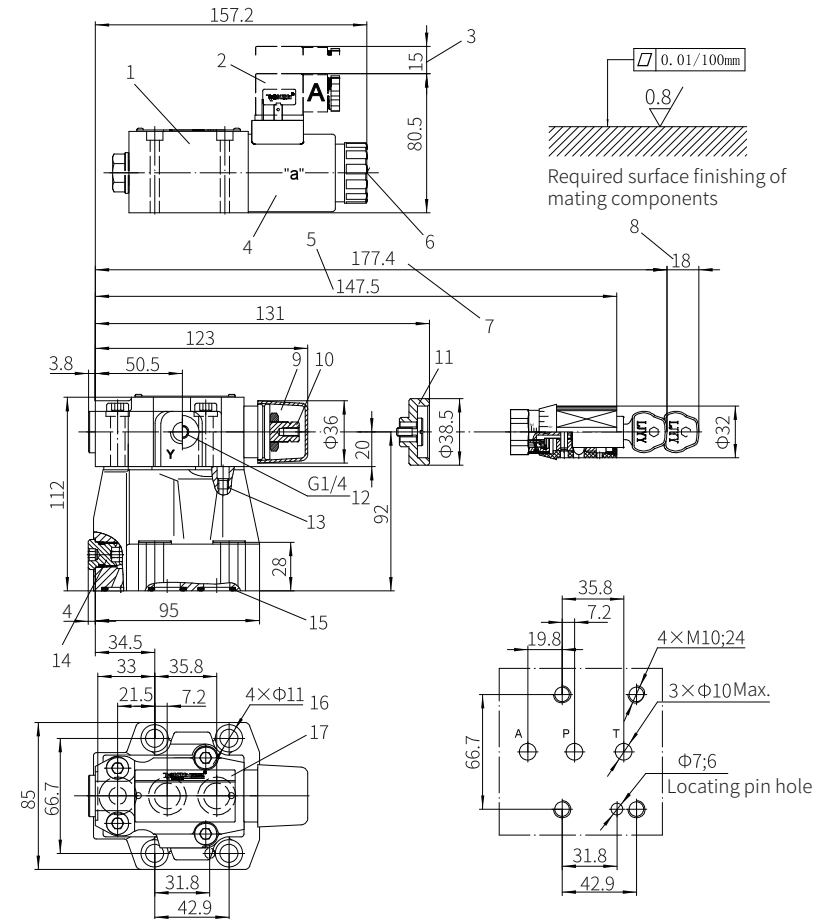

Valve fixing screw
M10x50-10.9 grade GB/T70.1-2000
Tightening torque $M_A=60\text{Nm}$

It must be ordered separately
if connection subplate is needed.
Subplate model:
G467/01; G467/02
G468/01; G468/02

- 1 Solenoid pilot valve
- 2 Plug
- 3 Space required to remove the plug
- 4 Solenoid
- 5 Adjustment form "7"
- 6 Hidden emergency operation
- 7 Adjustment form "5"
- 8 Space required to remove the key
- 9 Adjustment form "2"
- 10 Hexagon S=10
- 11 Adjustment form "1"
- 12 Port Y for control oil drain external
- 13 Omitted with internal pilot oil drain
- 14 Built-in check valve
- 15 O ring 17.12x2.62
- 16 Valve fixing screw hole
- 17 Name plate

Component size

Size unit: mm

Model DA20...-5XJ/...and DA30...-5XJ/...

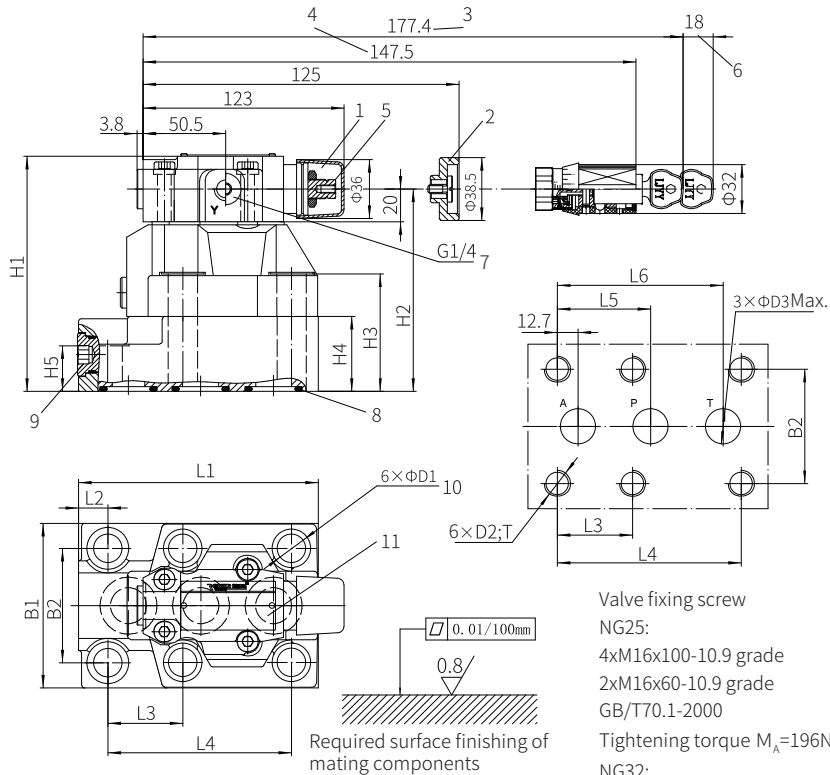

Size	L1	L2	L3	L4	L5	L6	H1	H2	H3
25	147	18	46	112.7	57.1	101.6	144	124	72
32	189.2	32	50.8	139.7	63.5	127	165	145	93
Size	H4	H5	B1	B2	D1	D2	D3	T	
25	46	28	101	69.9	18	M16	22	34	
32	67	45	116	82.5	20	M18	30	37	

It must be ordered separately if connection subplate is needed.

Subplate model:

NG25: G469/01; G469/02; G470/01; G470/02

NG32: G471/01; G471/02; G472/01; G472/02

Valve fixing screw
NG25:
4xM16x100-10.9 grade
2xM16x60-10.9 grade
GB/T70.1-2000
Tightening torque $M_A=196\text{Nm}$
NG32:
4xM18x120-10.9 grade
2xM18x80-10.9 grade
GB/T70.1-2000
Tightening torque $M_A=260\text{Nm}$

1 Adjustment form "1"
2 Adjustment form "2"
3 Adjustment form "5"
4 Adjustment form "7"
5 Hexagon S=10
6 Space required to remove the key
7 Port Y for control oil drain external
8 O ring
9 Built-in check valve
10 Valve fixing screw hole
11 Name plate

Component size

Size unit: mm

With (DAC30) or without (DAC)

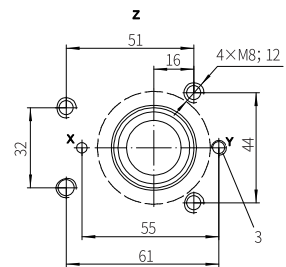
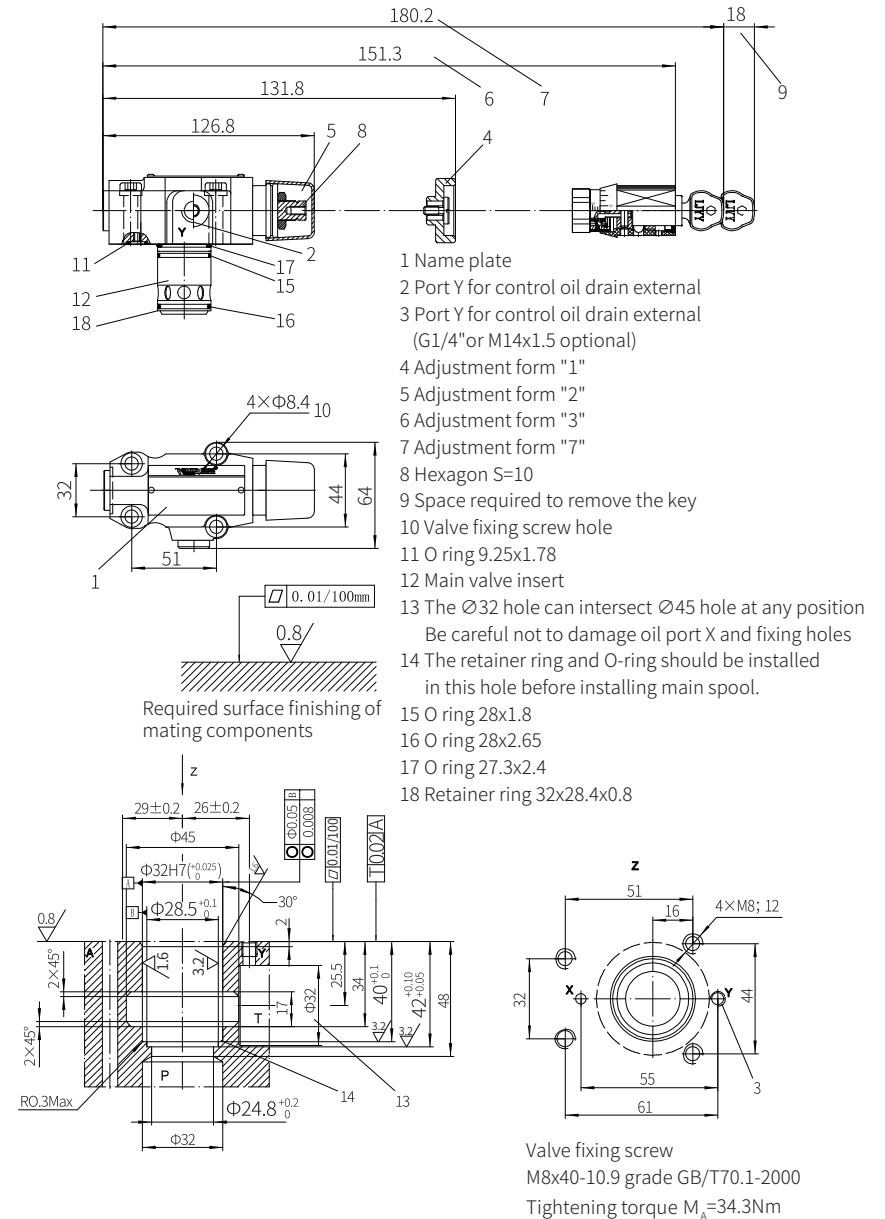

Valve fixing screw
M8x40-10.9 grade GB/T70.1-2000
Tightening torque $M_A=34.3\text{Nm}$

Application example

Hydraulic system with accumulator:

installation notes:

- The connection resistance between DA valve and accumulator must be as low as possible
- The pilot valve of DA is separately connected to the accumulator when the resistance is high.

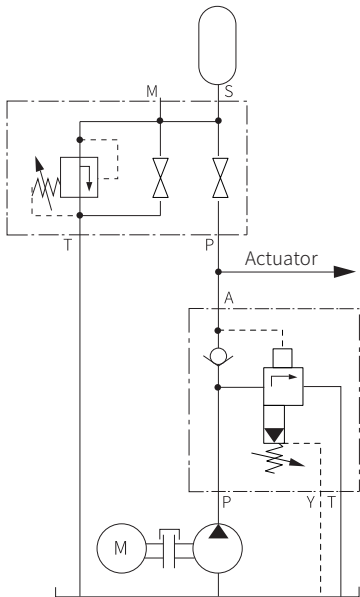

Hydraulic system with high and low pressure pump:
With high pump flow and small switching pressure differential values (10%), "Y" version valves should preferably be used.

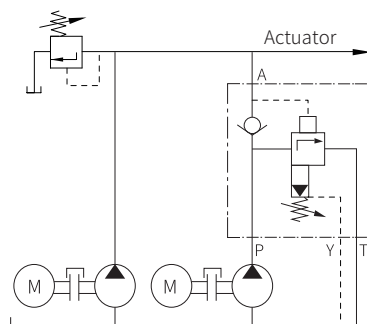

Explosion-proof Multistage Electro-hydraulic Pilot Relief Valve

Model: G-DB2U...-5XJ

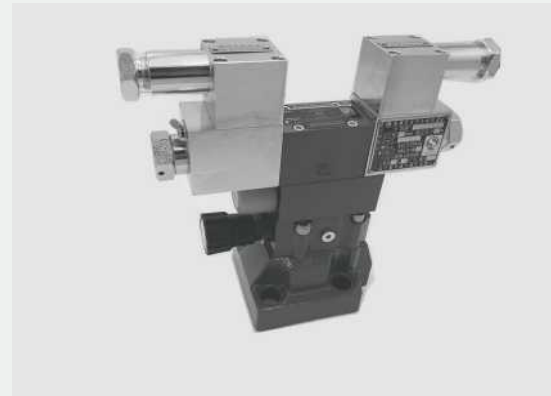

- ◆ Size 10 to 32
- ◆ Maximum working pressure 350 bar
- ◆ Maximum flow rate 600 L/min

Contents

Function description, sectional drawing	02
Models and specifications	03
Functional symbols	04
Technical parameters	05
Characteristic curve	05-06
Component size	07-09

Features

- Subplate mounting
- Threaded connection
- Cartridge connection
- Two-stage pressure setting
- Controlled by solenoid directional valve
- Pressure adjusting forms:
 - Rotary knob
 - Internal hexagon screw with protective cap
 - Lockable rotary knob with scale.