

## Component size

Size unit: mm

Model DBT/DBWT...3XJ/...

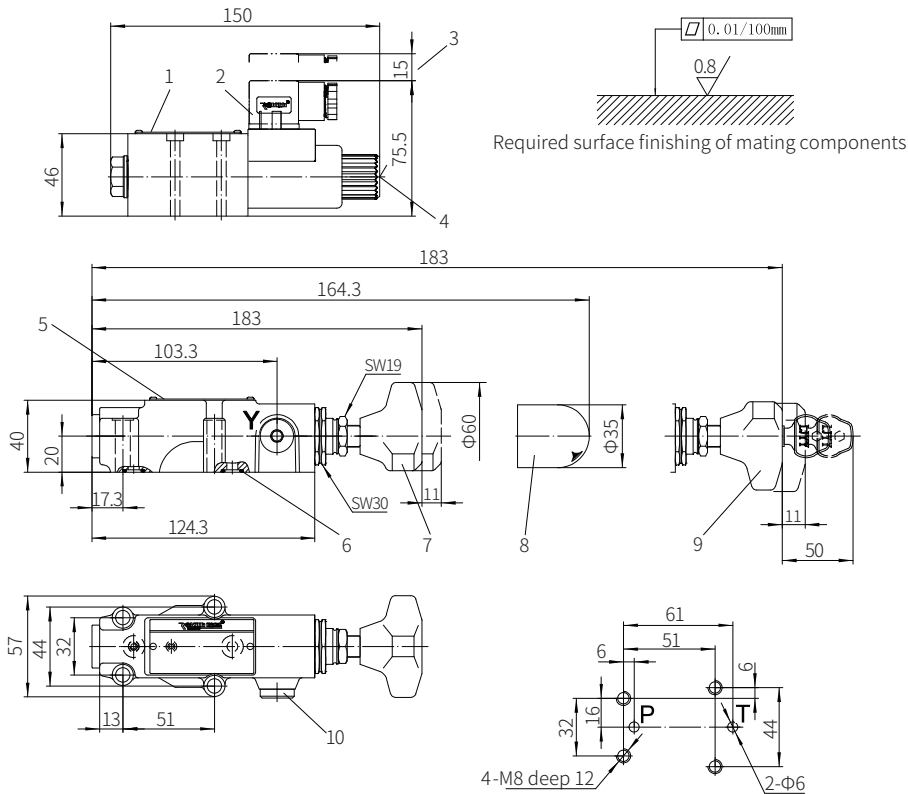

Valve fixing screw  
 M8x40-10.9 grade GB/T70.1-2000  
 Tightening torque  $M_A=34.3\text{Nm}$

- 1 DBWT name plate
- 2 Plug
- 3 Space required to remove the plug
- 4 Hidden emergency button
- 5 DBT name plate

- 6 O-ring 9.25x 1.78 (for port P, T)
- 7 Adjustment form "1"
- 8 Adjustment form "2"
- 9 Adjustment form "3"
- 10 External drain port (G1/4" or M14x1.5 optional)

## Direct Operated Relief Valve

Model: DBD...1XJ



- ◆ Size 6 to 30
- ◆ Maximum working pressure 630 bar
- ◆ Maximum working flow 330 L/min

## Contents

Function description, sectional drawing	02
Models and specifications	03
Technical parameters	04
Characteristic curve	05
Component size	06-08

## Features

- Inserted cartridge
- Threaded connection
- Subplate mounting
- 3 pressure adjustment elements
  - Inner hexagon adjusting screw with protective cap
  - Adjusting handle
  - Adjusting handle with lock

**Function description, sectional drawing**

The DBD pressure relief valve is direct operated, it is used to limit the pressure of hydraulic system.

The valve is composed of valve sleeve (1), spring (2), poppet spool (3) with damping (pressure grade 25 to 400 bar) or ball spool (4) (pressure grade 630bar) and pressure adjustment element (5). The system pressure can be set infinitely by the adjustment element (5). The spring (2) pushes the poppet spool (3) onto the valve seat. The channel P is connected to the system and system pressure affect on the area of poppet (or ball) spool.

If the pressure in channel P rises in excess of the value set at the spring (2), the poppet spool (3) or ball spool (4) will opens against the spring (2). The oil flows from channel P to channel T. The stroke of the poppet spool (3) is limited by a pin(6).

In order to gain the accurate setting value within the whole pressure range, the pressure scope is divided into 7 pressure ratings, and every pressure rating has a corresponding spring which may be set maximum pressure.

Model DBDS...K..1XJ/...  
Pressure grade 25 bar to 400 bar

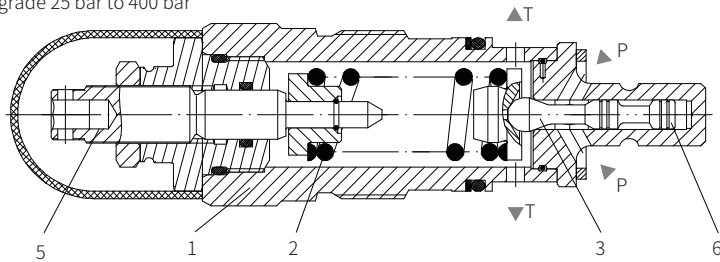

Model DBDH...K..1XJ/...  
Pressure grade 630 bar (poppet valve, only for size 10)

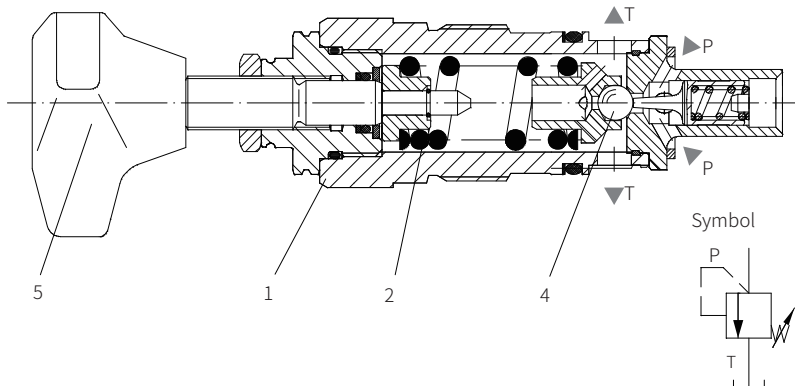

**Models and specifications**

		DBD									-1X		J						*		
direct operated relief valve																					
		Size																			
adjustment elements		6	8	10	15	20	25	30													
inner hexagon adjusting screw with protective cap		●	●	●	●	●	●	●	=S												
Adjusting handle		●	●	●	●	●	●	●	=H												
Adjusting handle with lock		●	●	●	●	●	—	—	=A												
size (connection)		=6 G1/4	=8 G3/8	=10 G1/2	=15 G3/4	=20 G1	=25 G1 1/4	=30 G1 1/2	=10												
connection type																					
inserted cartridge		●	—	●	—	●	—	●	=K												
threaded connection		●	●	●	●	●	●	●	=G												
subplate mounting		●	—	●	—	●	—	●	=P												
10 to 19 series (10 to 19 series installation and connection size unchanged)																					
Rekith																					
pressure grade																					
setting pressure up to 25 bar		●	●	●	●	●	●	●	=25												
setting pressure up to 50 bar		●	●	●	●	●	●	●	=50												
setting pressure up to 100 bar		●	●	●	●	●	●	●	=100												
setting pressure up to 200 bar		●	●	●	●	●	●	●	=200												
setting pressure up to 315 bar		●	●	●	●	●	●	—	=315												
setting pressure up to 400 bar		—	—	●	—	—	—	—	=400												
setting pressure up to 630 bar		—	—	—	—	—	—	—	=630												
G thread																					
metric thread (only for G type)																			=no code	=2	
sealing material																					
NBR seals																			=no code	=V	
FKM seals																			=no code	=V	
(consult for other seals)																			=no code	=V	
more information in text																					

● =available

## Technical parameters

Overview						
Size	6 and 8	10	15 and 20	25 and 30		
Installation position	Optional					
Environment temperature range	°C	-30 to +80 (NBR seal) -20 to +80 (FKM seal)				
Minimum strength of valve body material	The selection of valve body material has been included in the safety factor in all condition (e.g. referenced pressure strength, thread strength and tightening torques.)					
Hydraulic						
Maximum working pressure	-inlet port	bar	400	630	400	315
	-outlet port	bar	315	315	315	315
Maximum flow rate (standard valve)	See characteristic curve					
Oil fluid	Mineral oil (HL, HLP) <sup>1)</sup> in accordance with DIN 51524; Fast living organisms degraded oil according to VDMA 24568; HETG (Rapeseed oil) <sup>1)</sup> HEPG (Polyethylene glycol) <sup>2)</sup> HEES (synthetic ester) <sup>2)</sup>					
Oil temperature range	°C	-30 to +80 (NBR seal) -20 to +80 (FRM seal)				
Viscosity range	mm <sup>2</sup> /s	10 to 800				
Cleanliness of oil	The maximum allowable pollution level of oil is ISO4406 Class 20/18/15 <sup>3)</sup>					

<sup>1)</sup> For NBR seal and FKM seal

<sup>2)</sup> Only for FKM seal

<sup>3)</sup> The oil must meet the cleanliness degree requested by the components in the hydraulic system. Effect oil filtration can prevent failure and increase the service life of the components.

## Characteristic curve

(Measured when using HLP46,  $t_{oil} = 40^\circ\text{C} \pm 5^\circ\text{C}$ )

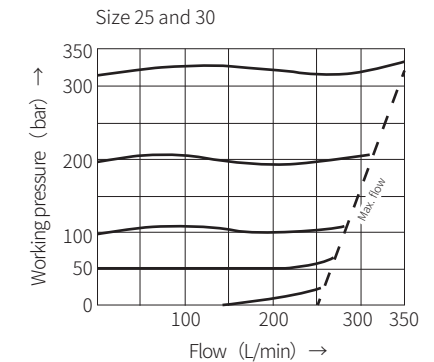
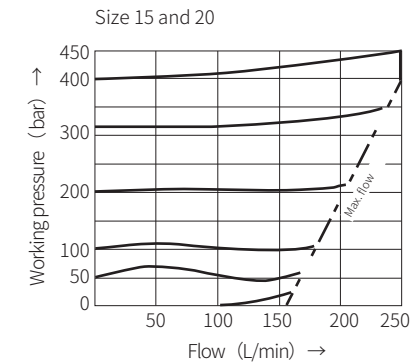
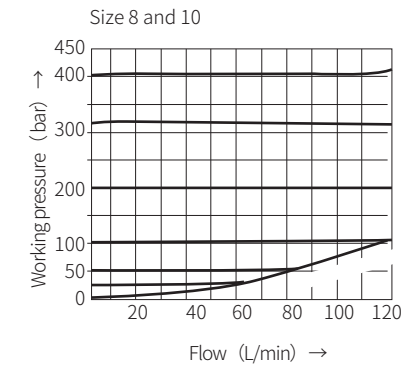
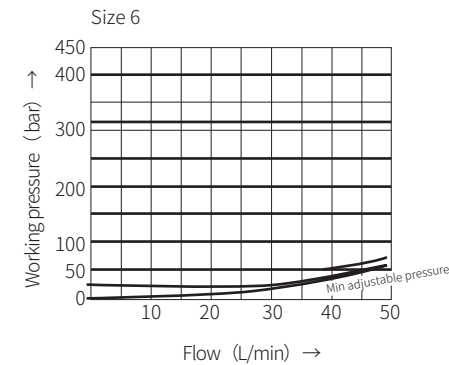

### Note:

- This characteristic curve is valid for outlet pressure = 0 over the entire flow range, but no related to the pressure drop in the housing when measuring.
- The characteristic curve is valid only under the environment and temperature conditions. It is necessary to consider that the characteristic curve is affected by changes in boundary conditions.

- This characteristic curve is associated with the given pressure grade (e.g. 200bar). The more the setting pressure value differs from the nominal pressure rating (e.g. <200bar), the pressure increases with the relief flow increases.

Component size

Size unit: mm

Subplate mounting valve

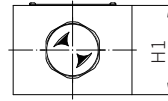
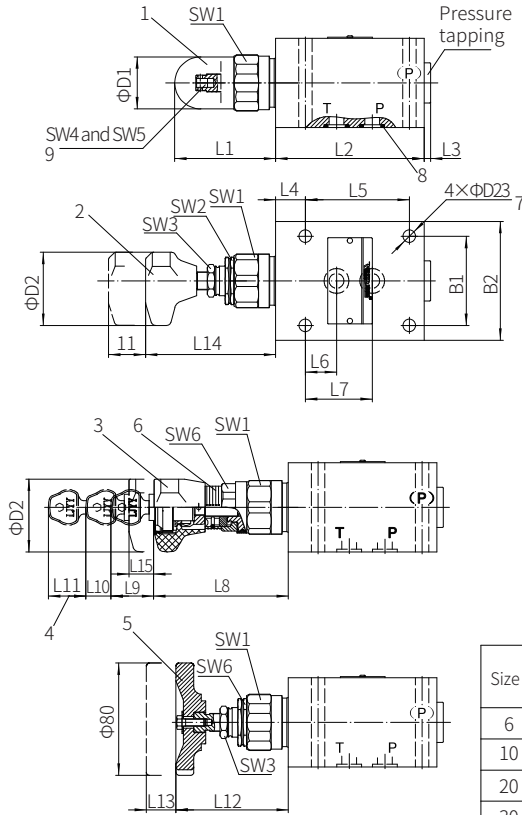

0.01/100mm

0.8/

Required surface finishing of mating components

- 1 Adjustment form "S"
- 2 Adjustment form "H"
- 3 Adjustment form "A"
- 4 Space required to remove the key
- 5 Butterfly handwheel (for size 25 and 30 only)
- 6 Ring with mark
- 7 Valve fixing hole
- 8 O-ring
- 9 Internal hexagon adjusting screw (SW4) S6 (NG6 to NG20)  
External hexagon adjusting screw (SW5) S13 (NG25 to NG30)

Size	O-ring (P, T)	Size of pressure tapping	Valve fixing screw (10.9)	Torque (Nm)
6	7×1.5	G1/4	M6×50	10
10	12.3×2.4	G1/2	M8×70	25
20	22×3	G3/4	M8×90	25
30	34×3	G1 1/4	M10×110	50

Size	L1	L2	L3	L4	L5	L6	L7	L8	L9	L10	L11	L12	L13
6	72	80	2	15	55	20	40	83	30	11	20	-	-
10	68	100	3	20	70	21	45	79	30	11	20	-	-
20	65	135	4	20	100	34	65	-	-	-	-	-	-
30	83	180	4	25	130	35	85	-	-	-	-	79.5	11

Size	L14	L15	B1	B2	H1	ΦD23	ΦD1	ΦD2	SW1	SW2	SW3	SW4	SW5	SW6
6	83	11	45	60	40	6.6	34	60	32	30	19	6	-	30
10	79	11	60	80	60	9	38	60	36	30	19	6	-	30
20	77	-	70	100	70	9	48	60	46	36	19	6	-	30
30	-	-	100	130	90	11	63	-	60	46	19	-	13	-

Component size

Size unit: mm

Threaded connection

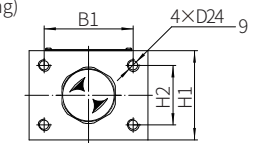
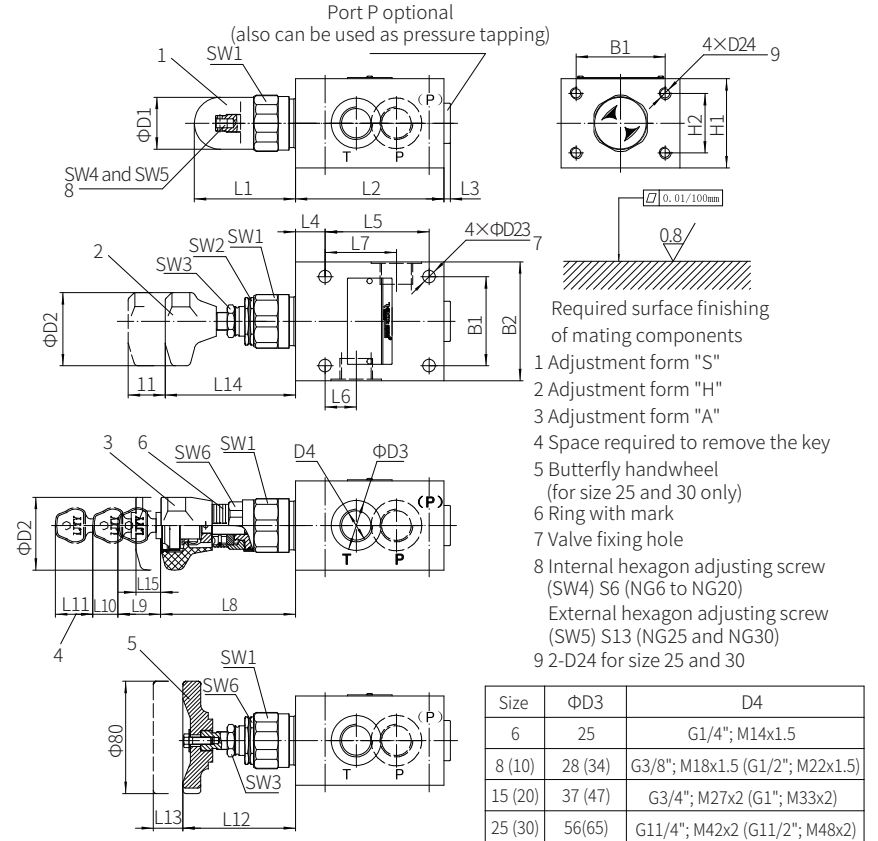

0.01/100mm

0.8/

Required surface finishing of mating components

- 1 Adjustment form "S"
- 2 Adjustment form "H"
- 3 Adjustment form "A"
- 4 Space required to remove the key
- 5 Butterfly handwheel (for size 25 and 30 only)
- 6 Ring with mark
- 7 Valve fixing hole
- 8 Internal hexagon adjusting screw (SW4) S6 (NG6 to NG20)  
External hexagon adjusting screw (SW5) S13 (NG25 to NG30)
- 9 2-D24 for size 25 and 30

Size	ΦD3	D4
6	25	G1/4"; M14x1.5
8 (10)	28 (34)	G3/8"; M18x1.5 (G1/2"; M22x1.5)
15 (20)	37 (47)	G3/4"; M27x2 (G1"; M33x2)
25 (30)	56(65)	G1 1/4"; M42x2 (G1 1/2"; M48x2)

Size	L1	L2	L3	L4	L5	L6	L7	L8	L9	L10	L11	L12	L13	D24
6	72	80	2	15	55	20	40	83	30	11	20	-	-	M6
8, 10	68	100	3	20	70	21	48	79	30	11	20	-	-	M8
15, 20	65	135	4	20	100	34	65	-	-	-	-	-	-	M8
25, 30	83	180	4	25	130	35	85	-	-	-	-	79.5	11	M10

Size	L14	L15	B1	B2	H1	ΦD23	ΦD1	ΦD2	SW1	SW2	SW3	SW4	SW5	SW6
6	83	11	45	60	40	6.6	34	60	32	30	19	6	-	30
8, 10	79	11	60	80	60	9	38	60	36	30	19	6	-	30
15, 20	77	-	70	100	70	9	48	60	46	36	19	6	-	30
25, 30	-	-	100	130	90	11	63	-	60	46	19	-	13	-

## Component size

Size unit: mm

Inserted cartridge valve

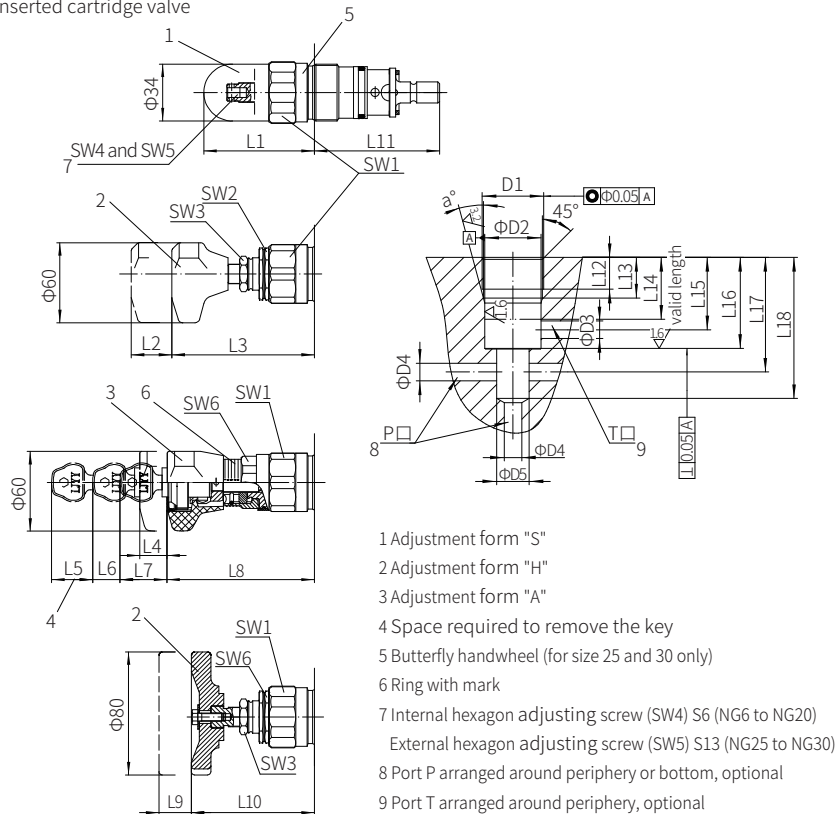

Size	L1	L2	L3	L4	L5	L6	L7	L8	L9	L10	L11	L12	L13
6	72	11	83	11	20	11	30	83	-	-	64.5	15	19
8, 10	68	11	79	11	20	11	30	79	-	-	77	18	23
15, 20	65	11	77	-	-	-	-	-	-	-	106	21	27
25, 30	83	-	-	-	-	-	-	-	11	79.5	131	23	29

Size	L14	L15	L16	L17	L18	ΦD1	ΦD2	ΦD3	ΦD4	ΦD5	a
6	39	35	45	56.5±15.5	65	M28×1.5	25H9	6	6	15	15
8, 10	35	41	52	67.5±7.5	80	M35×1.5	32H9	10	10	18.5	15
15, 20	45	54	70	91.5±8.5	110	M45×1.5	40H9	20	20	24	20
25, 30	45	60	84	113.5±11.5	140	M60×2	55H9	30	30	38.75	20

## Modular Pressure Relief Valve

Model: ZDB/Z2DB6...4XJ



- ◆ Size 6
- ◆ Maximum working pressure 315 bar
- ◆ Maximum working flow 60L/min

## Contents

Function description, sectional drawing	02
Models and specifications	02
Functional symbols	03
Technical parameters	03
Characteristic curve	04
Component size	05-07

## Features

- 4 pressure ranges
- 5 circuit options
- With one or two cartridge relief valves
- 4 adjustment elements
  - Rotary knob
  - Hexagon screw with sleeve and protective cap
  - Lockable rotary knob with scale
  - Rotary knob with scale