

Component size

Size unit: mm

with (DBC3U10 or 30) or without (DBC3U)

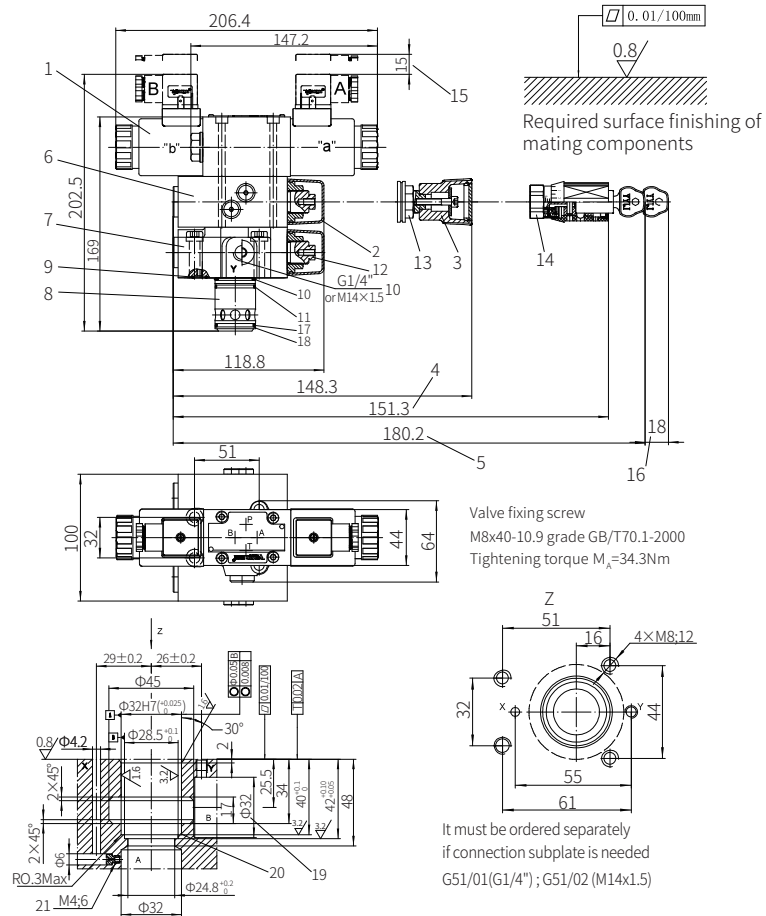

- | | |
|---|--|
| 1 Solenoid directional valve (type H, type D, optional) | 12 External hexagon screw S=10 |
| 2 Adjustment form "2" | 13 Hexagon nut S=24 |
| 3 Adjustment form "1" | 14 External hexagon screw S=24 |
| 4 Adjustment form "3" | 15 Space required to remove the plug |
| 5 Adjustment form "7" | 16 Space required to remove the key |
| 6 Secondary or tertiary pilot valve | 17 O ring 27.3x2.4 |
| 7 Primary pilot valve | 18 Retainer ring 32x28.4x0.8 |
| 8 Main spool | 19 The $\Phi 32$ hole can intersect $\Phi 45$ hole at any position |
| 9 O ring 9.25x1.78 | Be careful not to damage oil port X and fixing holes |
| 10 O ring 28x2.65 | 20 The retainer ring and O-ring should be installed in this hole before install main spool |
| 11 O ring 28x1.8 | 21 Throttle must be ordered separately |

Pilot Relief Valve/ Solenoid Pilot Relief Valve

Model: DB/DBW...5XJ



- ◆ Size 10 to 32
- ◆ Maximum working pressure 350 bar
- ◆ Maximum working flow 650L/min

Contents

Function description, sectional drawing	02-03
Models and specifications	04-05
Functional symbols	06
Technical parameters	07
Characteristic curve	08
Component size	09-11

Features

- Subplate mounting:
size 10/20/30
- Threaded connection:
size 10/15/20/25/32
- Setting pressure:
5MPa/10MPa/20MPa/31.5bar/35MPa
- Flow rate:
250L/min (for size 10 only)
500L/min (for size 15, 20, 25)
650L/min (for size 32 only)

Function description, sectional drawing

The DB and DBW pressure control valves are pilot operated relief valves. They are used to limit (DB), or to limit and unload by solenoids (DBW) of working pressure.

Pilot relief valve Model DB

This valve is basically composed of main valve (1) with main spool inserted (3) and pilot valve (2) with pressure adjustment element.

The pressure of port P acts on the main spool (3), meanwhile, the pressure is applied via control lines (6) and (7) with orifices (4) and (5) to the spring loaded side of the main spool (3) and on the ball (8) in the pilot valve (2). When the pressure in port P rises excess the spring setting pressure, the ball (8) overcomes the spring pressure (9) to open the pilot valve.

The signal is obtained internally via the control channels (10) and (6) from port P. The oil fluid on the spring loaded side of the main spool (3) flows into spring chamber (12) via control line (7), throttle (11) and ball (8). Thus, it flows internally via control line (13) into the tank for model DB, or flows externally via control line (14) into the tank for model DB..Y. Because of throttle (4) and (5), the pressure drop occurs at the main spool (3) and the connection from port P to port T is opened. The fluid flows from port P to port T while the setting working pressure is no changing. The pressure relief valve can unload or shift the different pressure (second pressure stage) by "X" port.

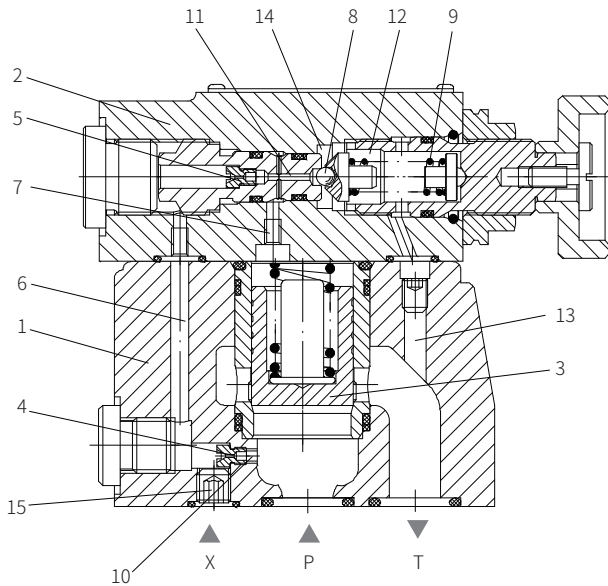

Model DB10-1-5XJ/

Function description, sectional drawing

Solenoid pilot relief valve Model DBW

In principle, the function of this valve is same with model DB.

But the unloading of the main spool (3) is achieved by operating the built-on directional valve (16).

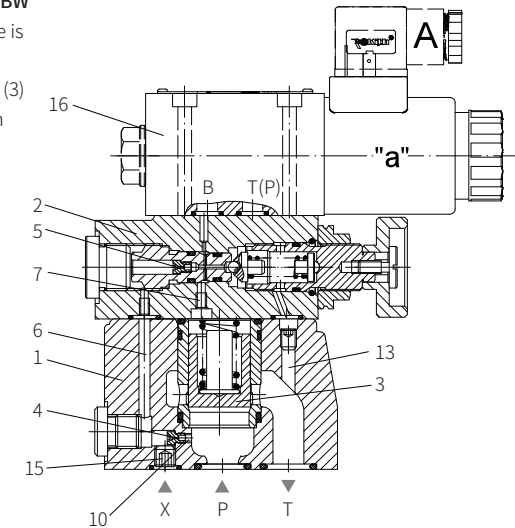

Model DBW10-1-5XJ/

Solenoid pilot relief valve with switching shock damping (sandwich), model DBW...S...R12

The connection from B2 to B1 opens with delay when switching shock damping valve (17) used, it can prevent pressure peaks and unloading shocks in the return line. The valve is installed between pilot valve and directional control valve (16). The degree of damping (unloading shock) depends on the size of throttle (18). Throttle $\varnothing 1.2\text{mm}$ is used as standard size (ordering code...R12...).

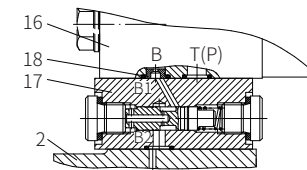
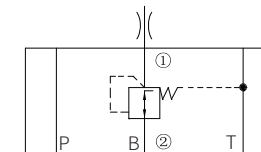
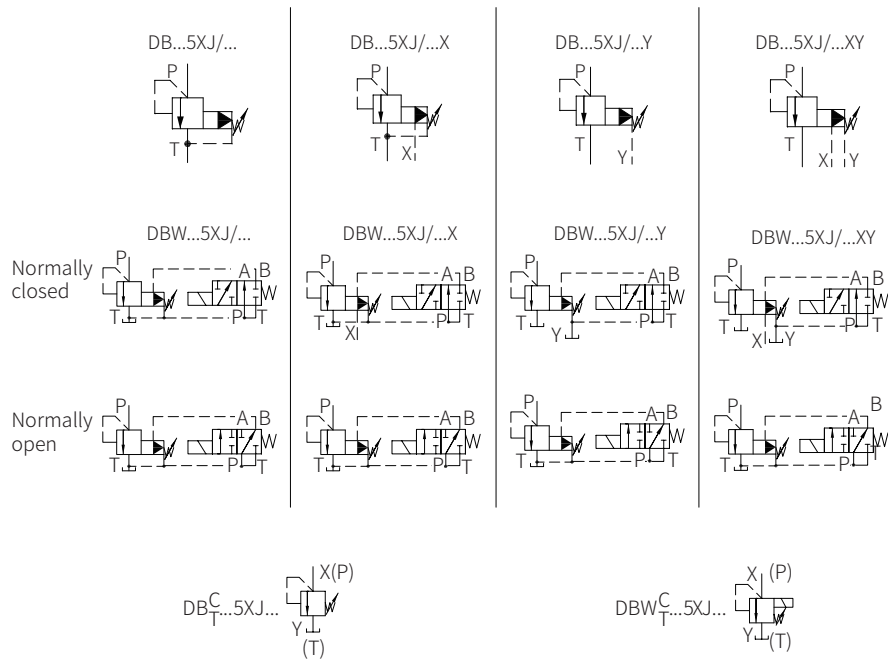

Illustration: directional valve opened



- The unloading function (directional valve function of DBW) cannot be used as safety function!
- When power off or cable breakage, Model DBW... B.. 5XJ/... should use the minimum setting pressure (circulation pressure).
- When power off or cable breakage, the pressure relief function of model DBW...A...5XJ/...is launched.
- The back pressure of pilot oil internal drain in port T or external drain in port Y is 1:1 added in pilot control pressure.

Functional symbols



02

Normally closed

Normally open

Technical parameters

Size	Size 10 DB..10	Size 15 DB..15G	Size 20 DB..20	Size 25 DB..25G	Size 32 DB..30		
Weight Subplate mounting	- DB...	Kg	2.6	-	3.5	-	4.4
	- DBW...	Kg	4.05	-	4.95	-	5.85
	- DBC...	Kg	1.2				
	- DBWC...	Kg	2.65				
	- DBC10 or 30...	Kg	1.5				
	- DBWC10 or 30 ...	Kg	2.95				
Threaded connection	- DB...G	Kg	5.3	5.2	5.1	5.0	4.8
	- DBW...G	Kg	6.75	6.65	6.55	6.45	6.25
Installation position	optional						
Environment temperature range	-DB...	°C	-30 to +50 (NBR seal)				-20 to +50 (FRM seal)
	-DBW...	°C	-30 to +50 (NBR seal)				-20 to +50 (FRM seal)
Minimum strength of valve body material (use for subplate mounting and DBC.../DBWC...valves)	The selection of valve body material has been included in the safety factor in all condition (e.g. referenced pressure strength, thread strength and tightening torques.)						
Hydraulic							
Maximum working pressure	- Oil port P, X	MPa	35.0				
	- Oil port T	MPa	31.5				
Maximum back pressure	- Oil port Y (DB)	MPa	31.5				
	- Oil port Y, T (DBW)	MPa	21.0 (DC solenoid) 16.0 (AC solenoid)				
Maximum setting pressure	MPa	5.0; 10.0; 20.0; 31.5; 35.0					
Minimum setting pressure	MPa	Interrelated with flow (see the curve)					
Maximum flow	Subplate mounting	L/min	250	-	500	-	650
	Threaded connection	L/min	250	500	500	500	650
Oil fluid	Mineral oil(HL,HLP) ¹⁾ in accordance with DIN 51524; fast living organisms degraded oil according to VDMA 24568; HETG(Rapeseed oil) ²⁾ ; HEPG(Polyethylene glycol) ²⁾ ; HEES(synthetic ester) ²⁾ ;						
Oil temperature range	°C	-30 to +80 (NBR seal) -20 to +80 (FRM seal)					
Viscosity range	mm ² /s	10 to 800					
Cleanliness of oil ³⁾	The maximum allowable pollution level of oil is ISO4406 Class 20/18/15						

1)For NBR seal and FKM seal

2)Only for FKM seal

3)The oil must meet the cleanliness degree requested by the components in the hydraulic system. Effect oil filtration can prevent failure and increase the service life of the components.

02

Component size

Size unit: mm

Threaded connection valve, model DB/DBW...G...-5XJ/...

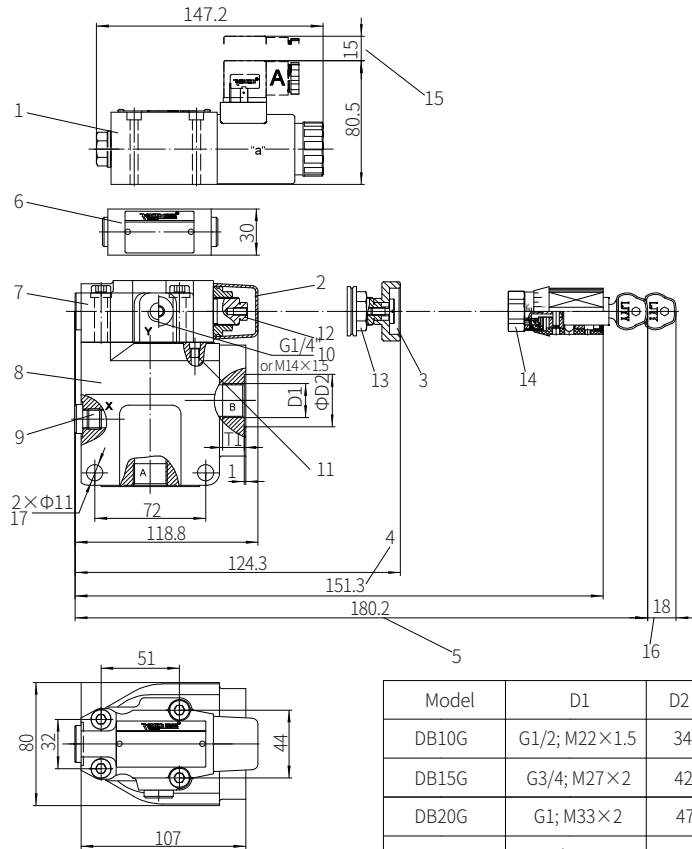

Model	D1	D2	T1
DB10G	G1/2; M22×1.5	34	14
DB15G	G3/4; M27×2	42	16
DB20G	G1; M33×2	47	18
DB25G	G1 1/4; M42×2	58	20
DB30G	G1 1/2; M48×2	65	22

- 1 Solenoid valve
- 2 Adjustment form "2"
- 3 Adjustment form "1"
- 4 Adjustment form "3"
- 5 Adjustment form "7"
- 6 With switching shock damping valve, optional
- 7 Primary pilot valve
- 8 Main valve
- 9 Port X for external pilot oil supply
- 10 Port Y for external pilot oil drain (G1/4" and M14x1.5 optional)
- 11 Omitted with internal pilot oil drain
- 12 External hexagon screw S=10
- 13 Hexagon nut S=24
- 14 External hexagon screw S=24
- 15 Space required to remove the plug
- 16 Space required to remove the key
- 17 Valve screw fixing holes

0412

Component size

Size unit: mm

Valve with (DB/DBWC10 or 30) or without (DBC/DBWC)

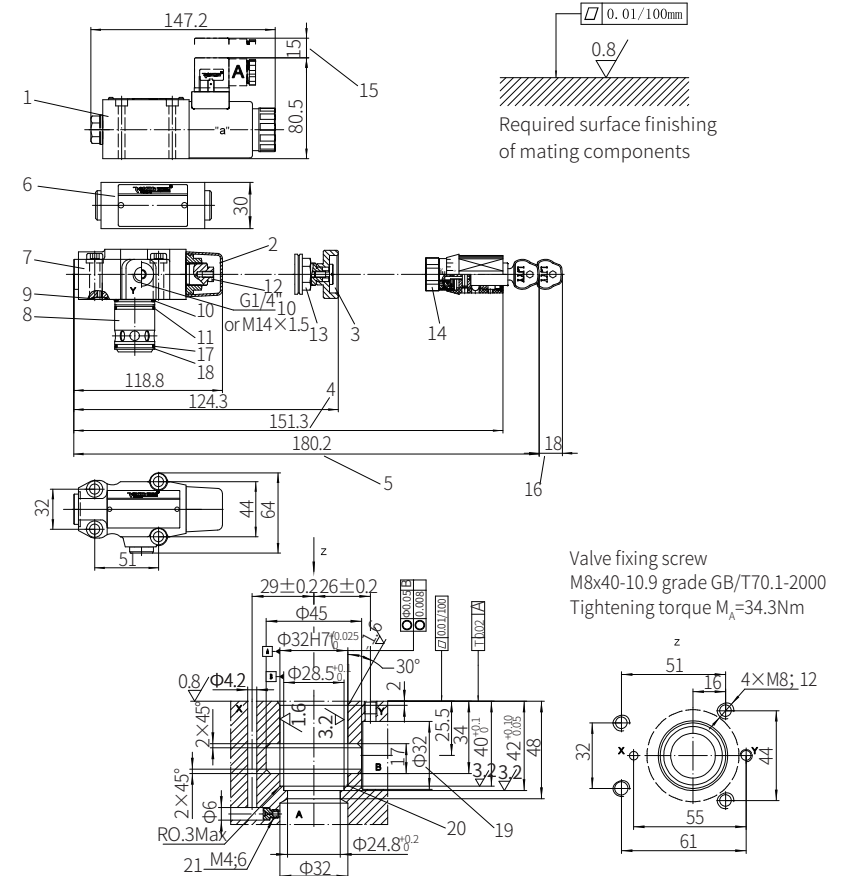

- 1 Solenoid valve
 - 2 Adjustment form "2"
 - 3 Adjustment form "1"
 - 4 Adjustment form "3"
 - 5 Adjustment form "7"
 - 6 With switching shock damping valve, optional
 - 7 Primary pilot valve
 - 8 Main spool
 - 9 O-ring 9.25x1.78
 - 10 O-ring 28x2.65
 - 11 O-ring 28x1.8
 - 12 External hexagon screw S=10
 - 13 Hexagon nut S=24
 - 14 External hexagon screw S=24
 - 15 Space required to remove the plug
 - 16 Space required to remove the key
 - 17 O-ring 27.3x2.4
 - 18 Retainer ring 32x28.4x0.8
 - 19 The $\Phi 32$ hole can intersect $\Phi 45$ hole at any position. Be careful not to damage oil port X and fixing holes.
 - 20 The retainer ring and O-ring should be installed in this hole before installing main spool.
 - 21 Throttle must be ordered separately.
- It must be ordered separately if connection subplate is needed.
G51/01 (G1/4"); G51/02 (M14x1.5)

0413