

## Direct Operated Pressure Reducing Valve

Model: DR5DP...1XJ



- ◆ Size 5
- ◆ Maximum working pressure 315 bar
- ◆ Maximum working flow 15 L/min

### Contents

Function description, sectional drawing	02
Models and specifications	02
Functional symbols	03
Technical parameters	03
Characteristic curve	04
Component size	05

### Features

- Mounting surface according to DIN 24340 form C
- Subplate mounting
- Panel mounting
- 5 pressure ratings
- 3 adjustment elements
- Check valve, optional

Any part of this brochure can not be reproduced, edited, copied and disseminated electronically in any way without authorization of Jiayite Hydraulics company. As the product is in constant development and innovation, the information in this brochure is not specific to the special conditions or applicability of a specific industry, thus Jiayite Hydraulics company is not responsible for any incomplete or inaccurate description generated.



## Function description, sectional drawing

The DR5DP valve is a 3-way direct operated pressure reducing valve and used to reduce the pressure of circuit.

It is composed of valve body (1), control spool (2), compression spring (3), adjusting element (4), and an optional check valve(5). The secondary pressure is set via the adjusting element (4).

At rest, the valve is normally open, the fluid can flow freely from port P to port A. The pressure at port A acts on the spool face of compression spring(3) via control line (6) and orifice(7). When the pressure at port A exceeds the setting value of the compression spring (3), the control spool (2) moves into the control position and the pressure at ports A remains constant. The control oil are supplied internally from port A, and also can be supplied externally via the port X.

If the pressure at port A continues to increase due to external force, the control spool (2) will still move towards the compression spring (3), then the port A is drained to the oil tank via the shoulder (8) to prevent further pressure increase. The control oil in the spring chamber is drained external to the oil tank through the port Y(T).

An optional check valve (5) allows the fluid to flow freely from port A to port P.

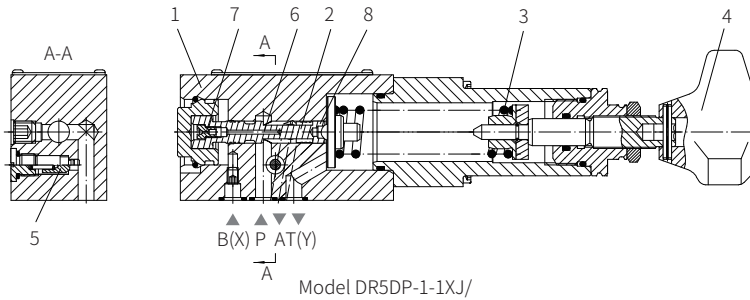

## Models and specifications

DR5DP	-1X	J	*
subplate mounting =No code panel mounting =F			
direct operated pressure reducing valve, size 5			more information in text
rotary knob = 1 adjusting screw with protective cap = 2 lockable rotary knob with scale = 3			sealing material No code= NBR seals V= FKM seals (consult for other seals)
10 series (10 to 19 series: installation and connection size unchanged)	=1X		No code= with check valve M= without check valve
Rekith		=J	Y= pilot oil supply internal, drain external XY= pilot oil supply external, drain external
			25= maximum secondary pressure 25bar 75= maximum secondary pressure 75bar 150= maximum secondary pressure 150bar 210= maximum secondary pressure 210bar 315= maximum secondary pressure 315bar (315 bar only for type without check valve)

## Functional symbols

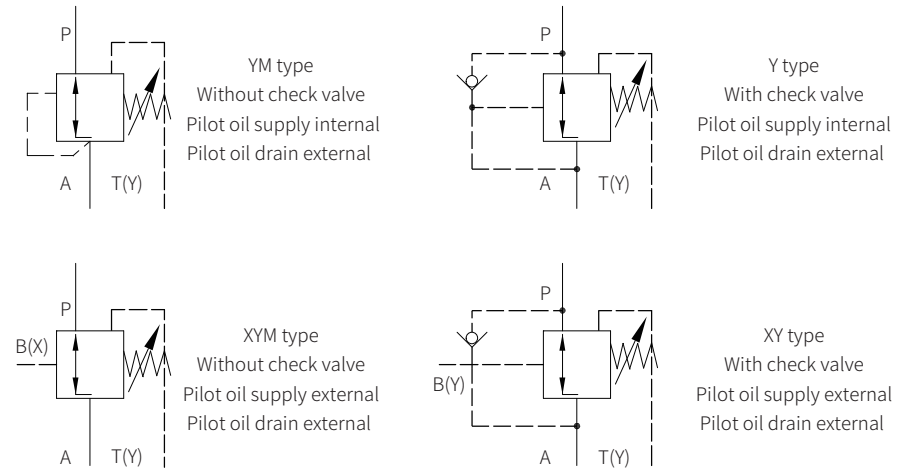

## Technical parameters

Hydraulic oil	Mineral oil(HL, HLP) according to DIN 51 524; Phosphate oil(HFD-R)
Hydraulic oil temperature range °C	-30 to +80 (NBR seal) -20 to +80 (FKM seal)
Viscosity range mm <sup>2</sup> /s	10 to 800
Cleanliness of oil	The maximum allowable pollution level of oil is ISO4406 Class 20/18/15
Working pressure port P bar	to 315
Secondary pressure port A bar	to 25; to 75; to 150; to 210; to 315 (without check valve)
Backpressure port T(Y) bar	to 60
Maximum flow L/min	to 15
Weight Kg	about 1.2

## Characteristic curve

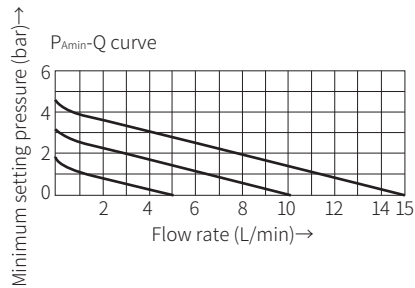
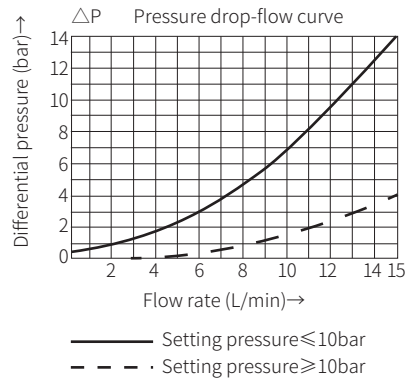
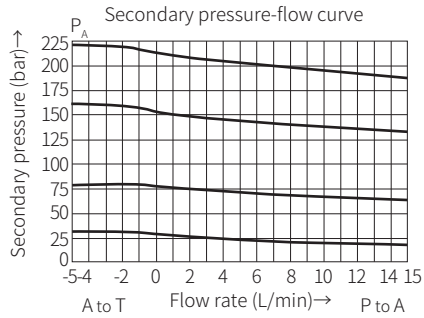
(Measured when using HLP46,  $\vartheta_{oil}=40^{\circ}\text{C} \pm 5^{\circ}\text{C}$ )

The  $P_{Amin}$ -Q curve represents the relationship between the minimum setting pressure and the flow-rate from P to A.

For example: when pressure is 25 bar and flow-rate is 10L/min, the pressure at port A is set 20 bar, when the secondary pressure increase to 23 bar, the flow-rate decreases to near zero.

## Component size

Size unit: mm

Model DR5DP...-1XJ/...

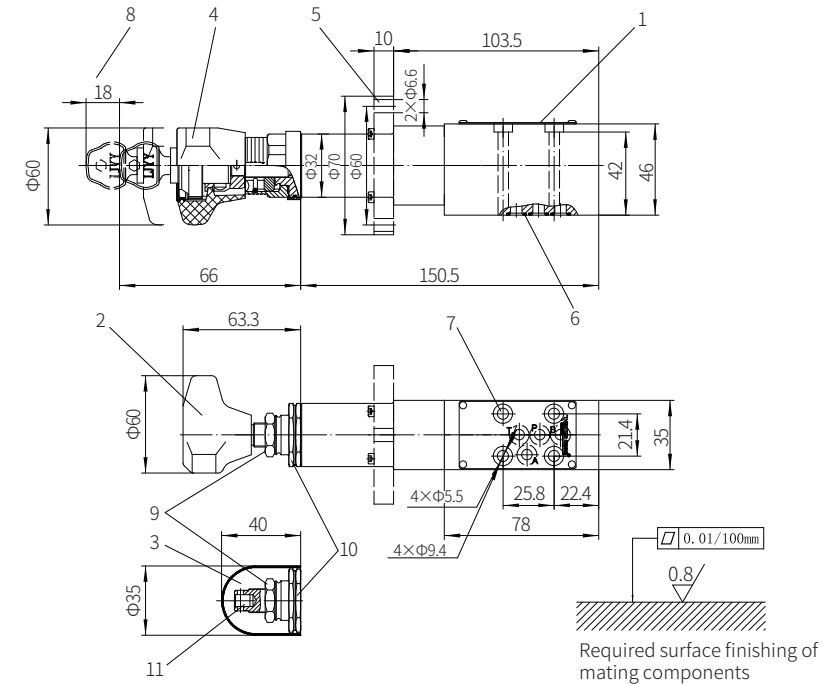

- 1 Name plate
- 2 Adjustment unit "1"
- 3 Adjustment unit "2"
- 4 Adjustment unit "3"
- 5 Panel mounting flange
- 6 O ring 7x1.5 (for oil port P, A, B, T)
- 7 Valve fixing screw hole
- 8 Space required to remove the key
- 9 Locknut S=24
- 10 Hexagon S=10
- 11 Internal hexagon adjusting screw S=6

Valve fixing screw  
M5x50-10.9 grade GB/T70.1-2000  
Tightening torque  $M_A=13.7\text{Nm}$

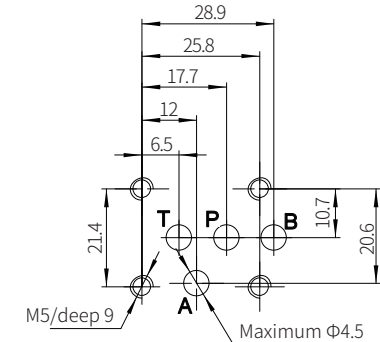

It must be ordered separately if connection subplate is needed.  
Subplate model:  
G115/01 (G1/4") ; G115/02 (M14x1.5)