

Component size

Size unit: mm

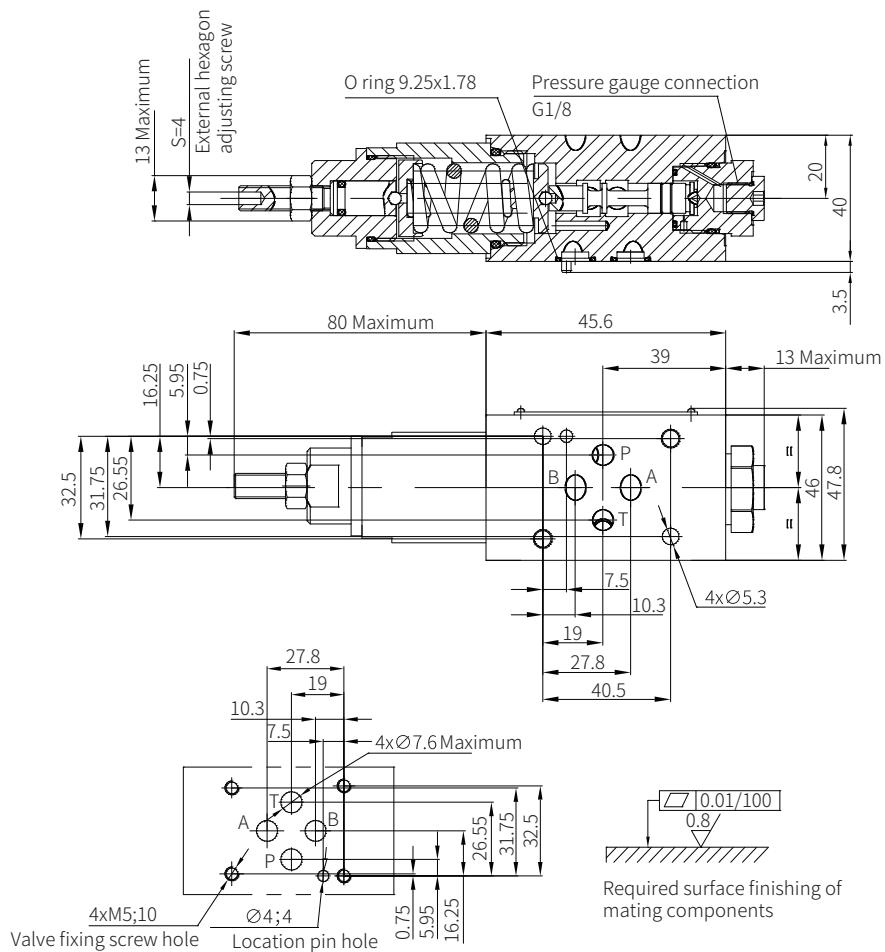

Valve fixing screw:

M5 -10.9 grade GB/T70.1, internal hexagon adjusting screw or LT30.02, stud with LT30.01 nut

Tightening torque $M_A=7.8$ Nm

The length is determined by the stacking height and it must be ordered separately.

Pilot Operated Pressure Sequence Valve

Model: DZ...5XJ



- ◆ Size 10, 25, 32
- ◆ Maximum working pressure 315 bar
- ◆ Maximum flow rate 600 L/min

Contents

| | |
|---|-------|
| Function description, sectional drawing | 02-03 |
| Models and specifications | 03 |
| Functional symbols | 04 |
| Technical parameters | 04 |
| Characteristic curve | 05-06 |
| Component size | 07-08 |

Features

- Use as pressure valve, sequence valve and bypass valve
- For subplate mounting
- 4 adjusting elements
 - Rotary knob
 - Adjusting screw with protective cap
 - Lockable rotary knob with scale
 - Rotary knob with scale
- 4 pressure ranges
- Check valve, optional

Function description, sectional drawing

The DZ pressure valve is pilot operated sequence valve, it is used for pressure dependent sequence switching of the secondary circuit. The valve is mainly composed of main valve (1) with main spool insert (7), pilot control valve (2) with pressure adjusting element, and an optional check valve(3).

The valve function varies according to pilot oil supply and drain configuration:

Preload valve model DZ...-5XJ/...(Control lines 4.1, 12 and 13 open; control lines 4.2, 14 and 15 closed)

The pressure in port A acts on the pilot spool (5) of the pilot valve(2) via the control line(4.1), and acts on the spring-loaded side of the main spool(7) via throttle (6) at the same time. When pressure exceeds the setting value of the spring (8), the pilot valve spool (5) is moved against spring (8). The control signal is obtained internally from port A via control line (4.1).

The fluid in spring chamber of main spool(7) via throttle (9), control shoulder (10), control lines (11) and (12) flow into port B. Thus, the pressure differential is formed at the main spool(7), the port A and port B is connected, and the setting value of the spring (8) remains unchanged. The leakage oil of the pilot valve spool (5) flows into port B internally via control line(13). An optional check valve (3) can be installed to allow the fluid flow freely from port B to port A.

Preload valve model DZ...-5XJ/..X...(Control lines 4.2, 12 and 13 open; control lines 4.1, 14 and 15 closed)
In principle, the function of this valve is same as model DZ... -5XJ/... but the signal is provided externally via control line (4.2) for model DZ...5XJ..X...

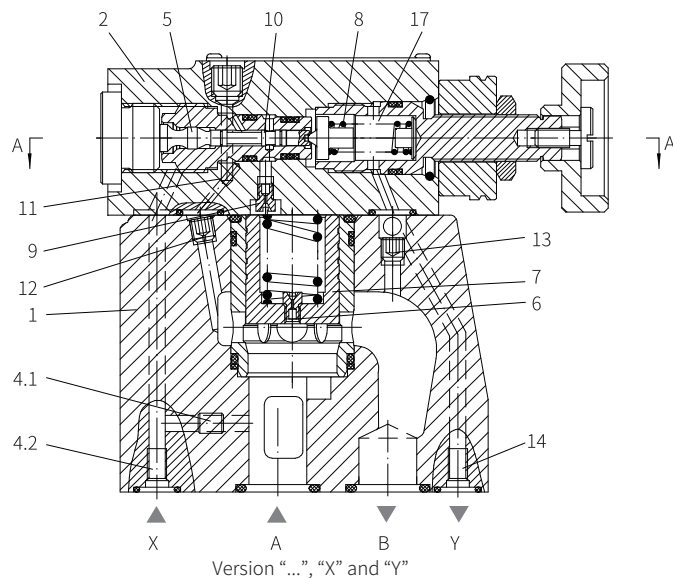

Function description, sectional drawing

Preload valve model DZ...-5XJ/..Y...(Control lines 4.1, 12, and 14 or 15 open; control lines 4.2 and 13 closed)
In principle, the function of this valve is same as model DZ... -5XJ/...

But for model DZ...5XJ..Y, the leakage at the pilot valve (5) must be drained to tank without pressure via control line (14) or (15), the pilot oil flows into port B via control line (12).

Preload valve model DZ...-5XJ/..XY...(Control lines 4.2, 14 or 15 open; control lines 4.1, 12 and 13 closed)

The pressure in port X acts on control piston (5) of pilot valve (2) via control line (4.2). At same time, the pressure in port A acts on spring chamber of main spool(7) via throttle (6). When the pressure in port X exceeds the setting value of the spring (8), the control piston (5) is moved against the spring (8), the fluid flows from spring chamber of main spool (7) to spring chamber (17) of pilot valve (2) via orifice (9) and hole (16). The pressure in spring chamber of main spool (7) decreases. Thus, the fluid can flow from port A to port B with minimum pressure lose. The control oil in spring chamber (17) should be drained to tank without pressure via control line (14) or (15). An optional check valve (3) can be installed to allow the fluid flow freely from port B to port A.

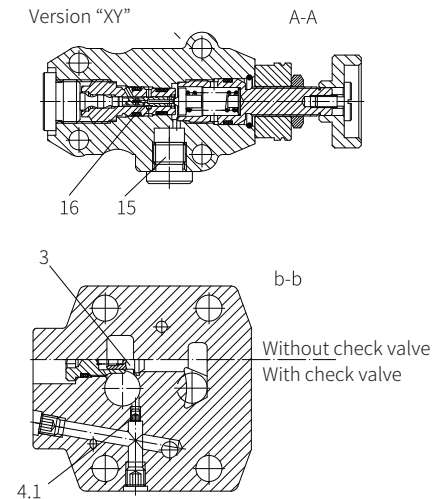

Models and specifications

| DZ | | -5X | | J | | * | |
|--|----------|-----|--|---|----|---|---|
| pilot valve | =No code | | | | | | more information in text |
| pilot valve without main spool insert (no mark for size) | =C | | | | | | sealing material No code= NBR seals V= FKM seals (consult for other seals) |
| pilot valve with main spool insert (mark for size 30) | =C | | | | | | |
| size 10 | =10 | | | | | | No code= with check valve M= without check valve |
| size 20 | =20 | | | | | | |
| size 30 | =30 | | | | | | |
| adjusting element | | | | | | | pilot oil supply |
| rotary knob | =1 | | | | | | No code= pilot oil supply and drain internal |
| adjusting screw with protective cap | =2 | | | | | | X= pilot oil supply external and drain internal |
| lockable rotary knob with scale | =3 | | | | | | Y= pilot oil supply internal and drain external |
| rotary knob with scale | =7 | | | | | | XY= pilot oil supply and drain external |
| 50 to 59 series | =5X | | | | | | 50= setting pressure up to 50 bar |
| (50 to 59 series installation and connection size unchanged) | | | | | | | 100= setting pressure up to 100 bar |
| | | | | | | | 200= setting pressure up to 200 bar |
| | | | | | | | 315= setting pressure up to 315 bar |
| Rekith | | | | | =J | | |

Functional symbols

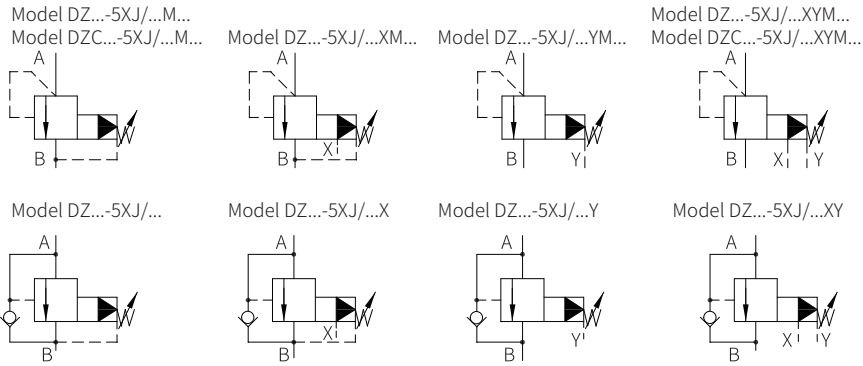

Technical parameters

| | | | | | |
|---------------------------------------|---|-----------------------|--|-----|-----|
| Installation position | | Optional | | | |
| Environment temperature range | | °C | -30 to +50 (NBR seal) -20 to +50 (FKM seal) | | |
| Weight | Size | | 10 | 25 | 32 |
| | DZ... | kg | 3.4 | 5.3 | 8.0 |
| | DZC... | kg | 1.2 | | |
| | DZC30... | kg | 1.5 | | |
| Hydraulic | | | | | |
| Maximum working pressure port A, B, X | bar | 315 | | | |
| Maximum backpressure port T | bar | 315 | | | |
| Setting pressure | Minimum | bar | flow-related (see characteristic curve) | | |
| | Maximum | bar | 50; 100; 200; 315 | | |
| Maximum flow | Size | | 10 | 25 | 32 |
| | | L/min | 200 | 400 | 600 |
| Medium | Mineral oil (HL, HLP) ¹⁾ in accordance with DIN 51524; Fast living organisms degraded oil according to VDMA 24568; HETG (Rapeseed oil) ¹⁾ ; HEPG (Polyethyleneglycol) ²⁾ ; HEES (Synthetic Fats) ²⁾ | | | | |
| Hydraulic oil temperature range | °C | -30 to +80 (NBR seal) | | | |
| | °C | -20 to +80 (FKM seal) | | | |
| Viscosity range | mm ² /s | 10 to 800 | | | |
| Cleanliness of oil ³⁾ | The maximum allowable pollution level of oil is ISO4406 Class 20/18/15 | | | | |

1) For NBR seal and FKM seal.

2) Only for FKM seal.

3) The oil must meet the cleanliness degree requested by the components in the hydraulic system.

Effective oil filtration can prevent failure and increase the service life of the components.

Characteristic curve

(Measured when using HLP46, $\vartheta_{oil}=40^{\circ}\text{C} \pm 5^{\circ}\text{C}$)

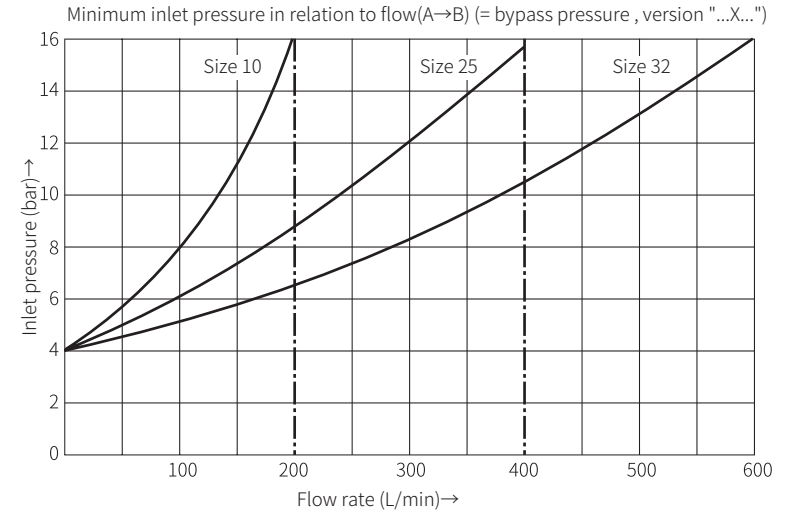
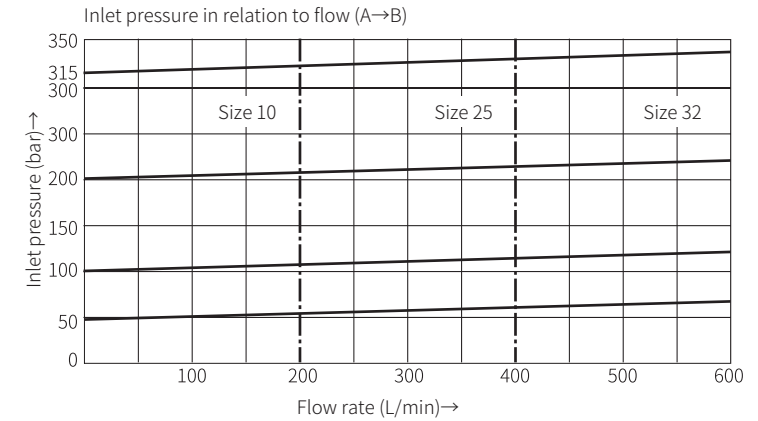

The curves are valid for outlet pressure $P_B=0$ over the entire flow range.

Component size

Size unit: mm

With (DZC10 or 30) or without DZC

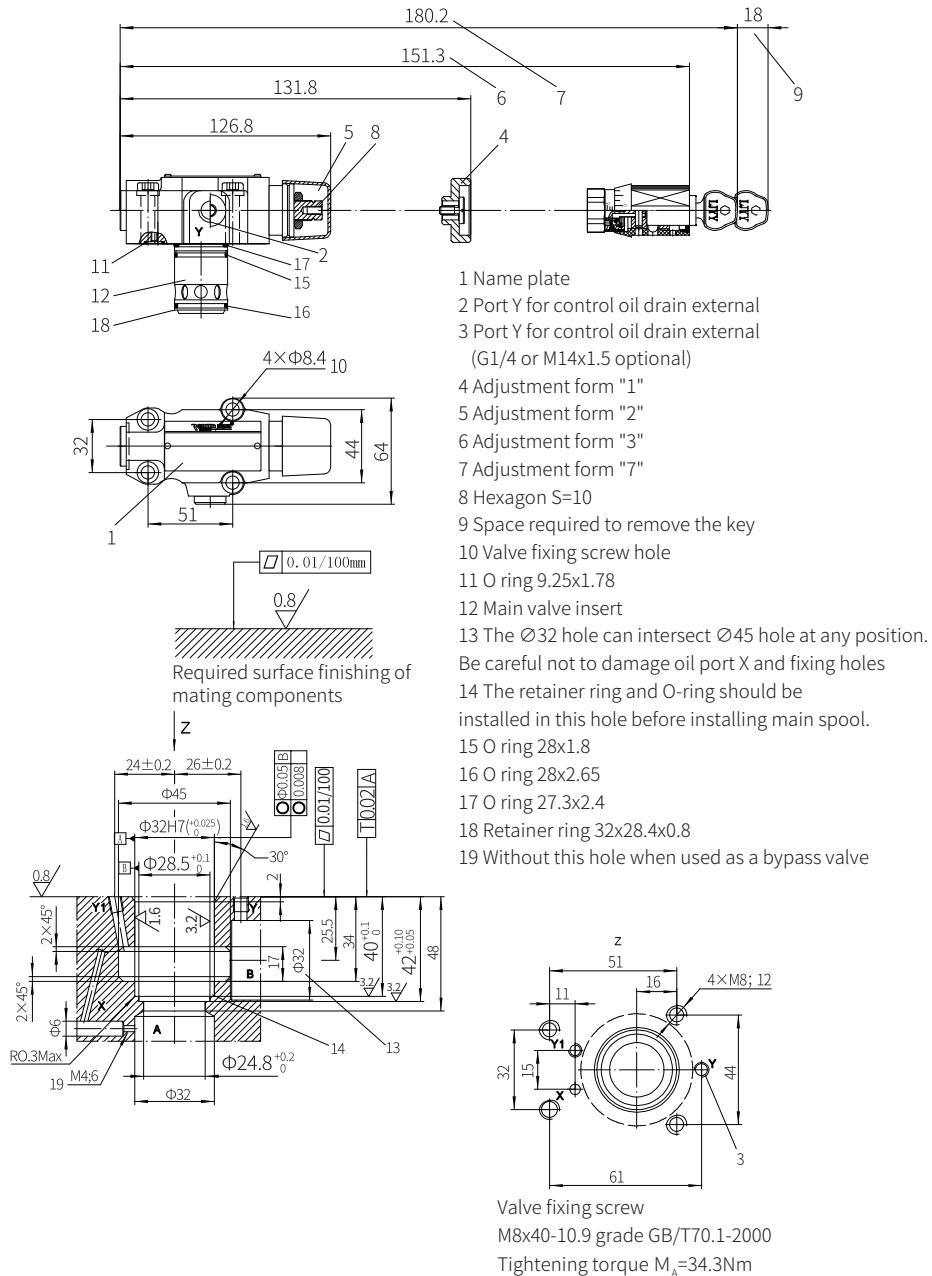

Pilot Operated Unloading Pressure Relief Valve

Model: DA/DAW...3XJ



- ◆ Size 10, 25, 32
- ◆ Maximum working pressure 315 bar
- ◆ Maximum flow rate 250 L/min

Contents

| | |
|---|-------|
| Function description, sectional drawing | 02-03 |
| Functional symbols | 03 |
| Models and specifications | 04 |
| Technical parameters | 05 |
| Characteristic curve | 06 |
| Component size | 07-08 |
| Application example | 09 |

Features

- For subplate mounting
- 3 adjusting elements
 Rotary knob
 Hexagon screw with sleeve and protective cap
 Lockable rotary knob with scale
- 3 pressure ranges
- Solenoid operated unloading by a built-on directional valve