

Balanced Valve

Model: FD...1XJ



- ◆ Size 12/16/25/32
- ◆ Maximum working pressure 315 bar
- ◆ Maximum working flow 560 L/min

Contents

Function description, sectional drawing	02
Circuit examples	03
Models and specifications	04
Functional symbols	04
Technical parameters	05
Characteristic curve	05
Component size	06-09

Features

- Pilot operated check valve no leakage
- The balanced valve controls the return flow Q_2 according to the flow Q_1 on the opposite side of the actuator
- With cylinders the area ratio ($Q_2=Q_1\phi$) must be considered
- By-pass valve, flow freely in the opposite direction
- External superimposed secondary pressure relief valve (for flange connection only)

Any part of this brochure can not be reproduced, edited, copied and disseminated electronically in any way without authorization of Jiayite Hydraulics company. As the product is in constant development and innovation, the information in this brochure is not specific to the special conditions or applicability of a specific industry, thus Jiayite Hydraulics company is not responsible for any incomplete or inaccurate description generated.



Function description, sectional drawing

The balanced valve is used to prevent "out of control" of hydraulic cylinder or motor caused by load in hydraulic system. It can also prevent pipe bursting.

The balanced valve mainly includes the valve body (1), main spool (2), pilot part (3), control spool (4), damping spool (5) and orifice (6). When lifting load, the fluid flows from A to B to open the main spool (2). If the load pressure fails (e.g. pipe break), the main spool closes immediately as the chamber (8) is connected with load pressure.

Lowering the load (circuit examples)

The direction of flow is from B to A. Port A is connected to tank through the directional valve. The piston rod side of the cylinder has a flow applied which corresponds to the working condition. The relationship between the control pressure at port X and the load pressure at port B is 1:20.

When the control pressure is reached, the main spool opens. The pilot body (3) is lifted off its seat by the control spool (4), and the chamber (8) is decompressed by its inner hole and port A to tank. At the same time, the load pressure in port B doesn't act on the chamber (8) any more due to the longitudinal movement of the pilot part (3) within the main spool. Then the main spool (2) is unloaded. The reverse side of the control spool (4) at the main spool (2) lies against the collar of the damping spool (5).

To open the main spool, the control pressure in port X depends on the spring in the chamber (9). When the valve opens, the pressure is 20bar, and it is 50bar when fully open. The relationship between the opening area, cracking pressure and differential pressure determines the flow to the actuator via the connection of B to A. It depends on the inlet flow on the other side of the actuator to prevent the actuator "runaway". The operation of the controlled lowering is not affected even if there is a pipe break between the directional valve and port A in the balanced valve.

Note on the opening and closing times of balanced valve:

- Throttling of the opening sequence is via orifice (6) in the control spool (4) and both sides of the damping spool (5).
- The closing of the balanced valve is almost no throttling.
- When being used together with cylinder, a throttle check valve (meter-out control) can be set in the control line of port X to affect the closing time.
- When being used together with the motor, a throttle check valve should not be set in the control line of port X, in this condition it is recommended to control the closing time of the direction valve.

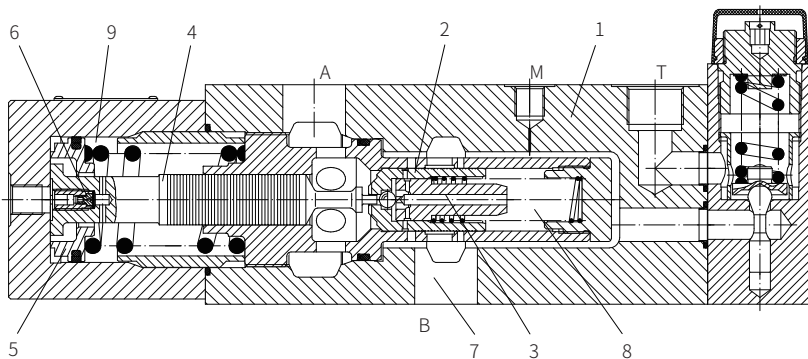

0646

Circuit examples

Cylinder with single rod

For safety, a closed center directional valve should be always used.

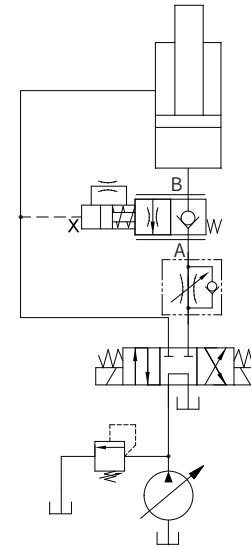

Note:

Two balanced valves can not be used to control two mechanically synchronized cylinder as it is impossible to maintain the same synchronized pressure in two cylinders. Therefore, it is necessary to install two hydraulic operated check valves type SL in the cylinder, and the balanced valve is installed in the common line. In this case, the load pressure can not exceed 200bar.

In order to avoid shaking caused by the loss of pressure at control port X because of fast falling speed, it is recommended to install a throttle check valve at port A of the balanced valve to limit the falling speed.

Hydraulic motor

To make sure the brake can be operated, the two oil ports of the directional valve must be connected to the tank in the neutral position. If the brake is externally operated, then it could use a closed central directional valve.

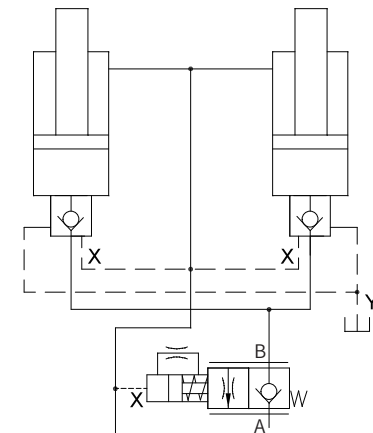
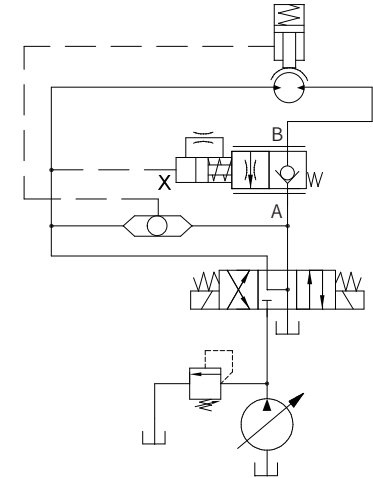

0647

Component size

Size unit: mm

Valves for manifold mounting (cartridge valves)

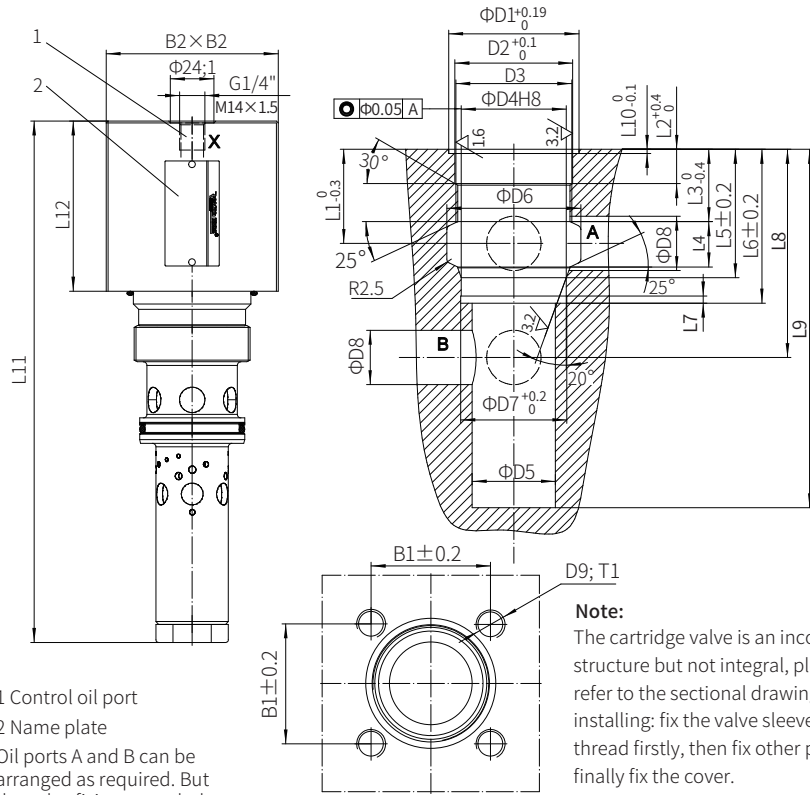

- 1 Control oil port
 - 2 Name plate
- Oil ports A and B can be arranged as required. But the valve fixing screw holes must not be damaged.

Model	B1	B2	D1	D2	D3	D4	D5	D6	D7	D8	D9	T1	L1	L2	L3	L4	L5
FD12KA	48	70	54	46	M42x2	38	34	46	38.6	16	M10	16	39	16	32	15.5	50.5
FD16KA	48	70	54	46	M42x2	38	34	46	38.6	16	M10	16	39	16	32	15.5	50.6
FD25KA	56	80	60	54	M52x2	48	40	60	48.6	25	M12	19	50	19	39	22	65
FD32KA	66	95	72	65	M64x2	58	52	74	58.6	30	M16	23	52	19	40	25	71

Model	L6	L7	L8	L9	L10	L11	L12	Valve fixing screw/Tightening torque	M_A (Nm)	Weight
FD12KA	60	3	78	128	2.3	191	65	four M10x70 GBT70.1-10.9	60	3.5kg
FD16KA	60	3	78	128	2.3	191	65	four M10x70 GB/T70.1-10.9	60	3.5kg
FD25KA	80	4	105	182	2.3	253	75	four M12x80 GB/T70.1-10.9	95	5.6kg
FD32KA	85	4	115	198	2.3	289	94	four M16x100 GB/T70.1-10.9	196	8.0kg

Component size

Size unit: mm

Subplate mounting

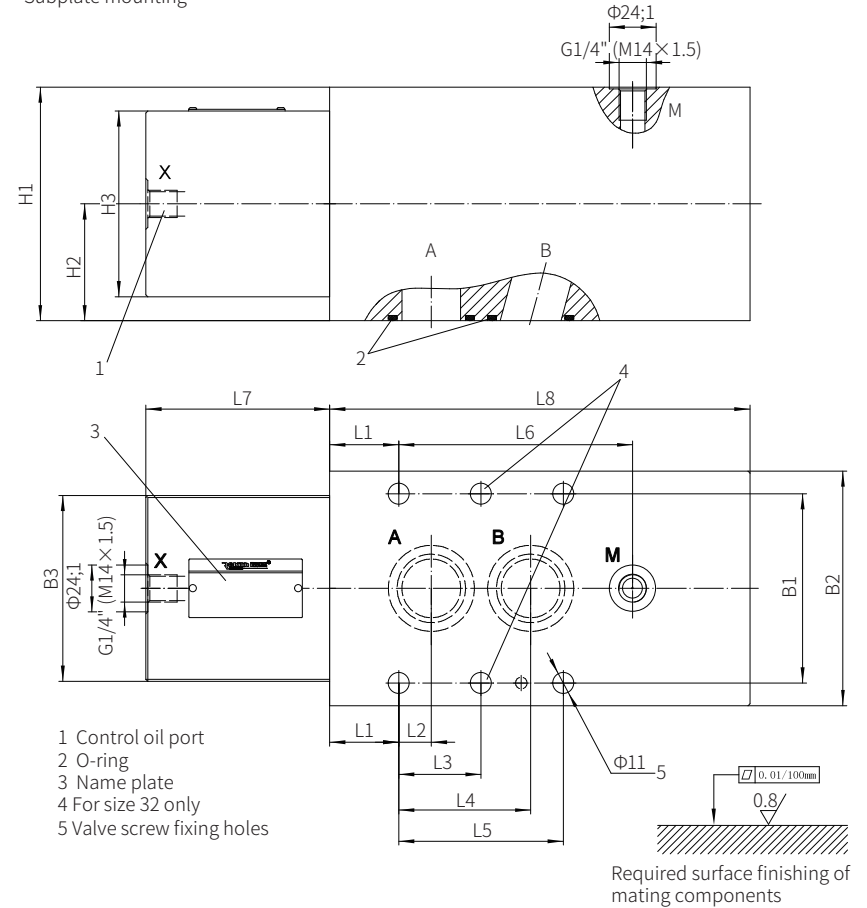

- 1 Control oil port
- 2 O-ring
- 3 Name plate
- 4 For size 32 only
- 5 Valve screw fixing holes

Model	B1	B2	B3	H1	H2	H3	L1	L2	L3	L4	L5	L6
FD12PA	66.7	85	70	85	42.5	70	31.8	7.2	-	35.8	42.9	73.2
FD16PA	66.7	85	70	85	42.5	70	31.8	7.2	-	35.8	42.9	73.2
FD25PA	79.4	100	80	100	50	80	38.9	11.1	-	49.2	60.3	109.1
FD32PA	96.8	120	95	120	60	95	35.3	16.7	42.1	67.5	84.2	119.7

Model	L7	L8	Valve fixing screw/Tightening torque	M_A (Nm)	Weight
FD12PA	65	140	four M10x100 GB/T70.1-10.9	60	9.3kg
FD16PA	65	140	four M10x100 GB/T70.1-10.9	60	9.3kg
FD25PA	75	200	four M10x120 GB/T70.1-10.9	60	18kg
FD32PA	94	215	four M10x140 GB/T70.1-10.9	60	28kg

Component size

Size unit: mm

For SAE flange connection,
without secondary pressure relief valve

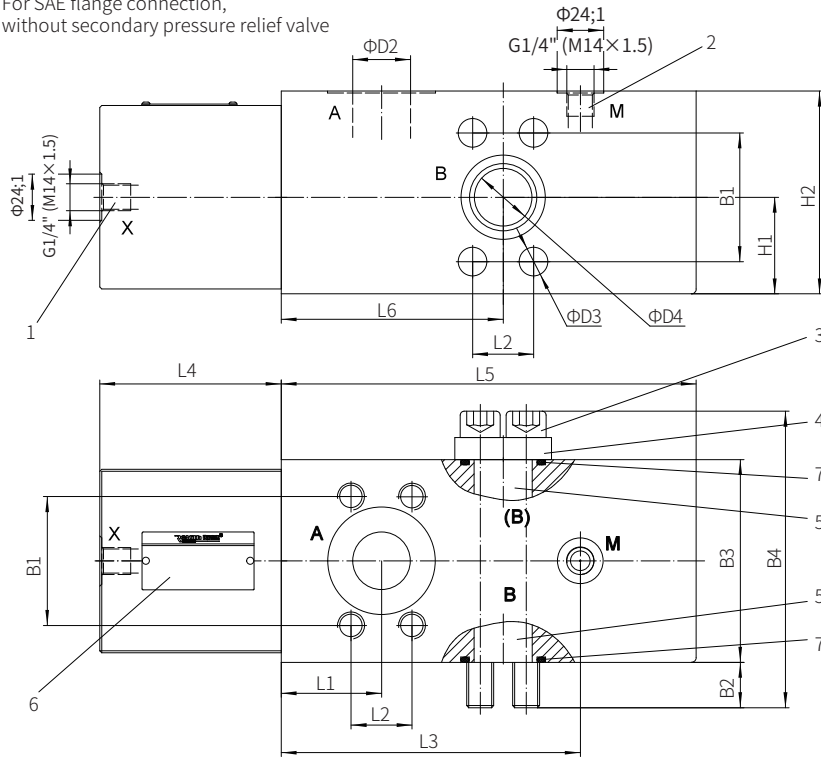

- 1 Control oil port
- 2 Measuring port
- 3 Flange fixing screw
- 4 Blanking flange
- 5 Optional port B
- 6 Name plate
- 7 O-ring

Model	B1	B2	B3	B4	D1	D2	D3	D4	D5	H1	H2	L1	L2	L3	L4
FD12FA	50.8	16.5	72	110	43	18	10.5	18	M10	36	72	39	23.8	105	65
FD16FA	50.8	16.5	72	110	43	18	10.5	18	M10	36	72	39	23.8	105	65
FD25FA	57.2	14.5	90	132	50	25	13.5	25	M12	45	90	50	27.8	148	75
FD32FA	66.7	20	105	154	56	30	15	30	M14	50	105	52	31.8	155	94

Model	L5	L6	T1	Weight	O-ring (7)	Valve fixing screw
FD12FA	140	78	15	7.2kg	25x3.5	4 pcs M10x100 GB/T70.1-10.9
FD16FA	140	78	15	7.2kg	25x3.5	4 pcs M10x100 GB/T70.1-10.9
FD25FA	200	105	18	16kg	32.92x3.53	4 pcs M12x120 GB/T70.1-10.9
FD32FA	215	115	21	23kg	37.7x3.53	4 pcs M14x140 GB/T70.1-10.9

Component size

Size unit: mm

For SAE flange connection,
with secondary pressure relief valve

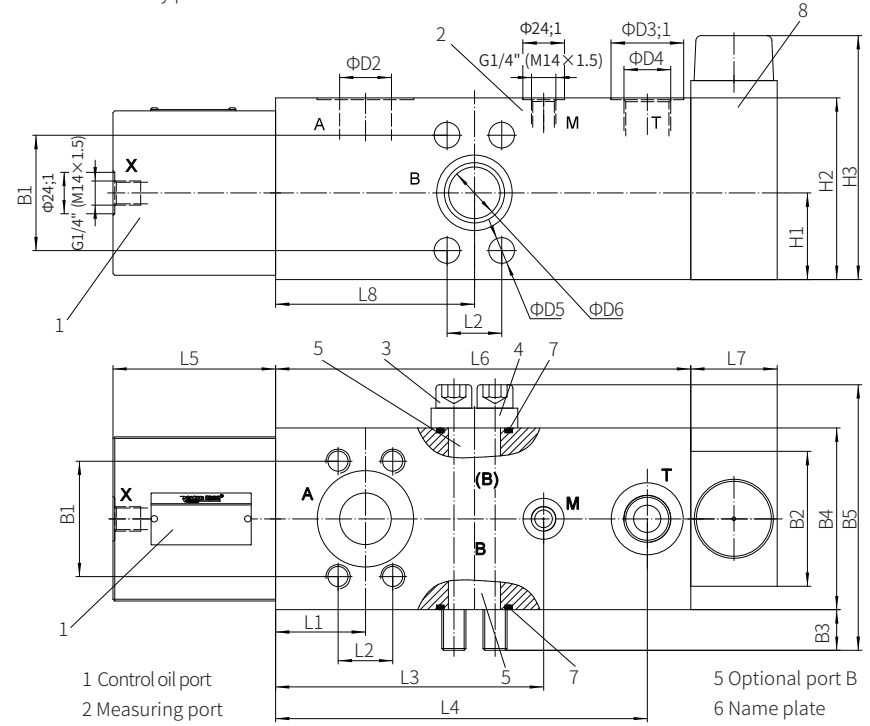

- 1 Control oil port
- 2 Measuring port
- 3 Flange fixing screw
- 4 Blanking flange
- 5 Optional port B
- 6 Name plate
- 7 O-ring
- 8 Safety valve

Model	B1	B2	B3	B4	B5	D1	D2	D3	D4		D5	D6	D7	H1	H2	H3	L1
									G	Metric							
FD12FB	50.8	49	16.5	72	110	43	18	34	G1/2	M22x1.5	10.5	18	M10	36	72	118	39
FD16FB	50.8	49	16.5	72	110	43	18	34	G1/2	M22x1.5	10.5	18	M10	36	72	118	39
FD25FB	57.2	78	14.5	90	132	50	25	42	G3/4	M27x2	13.5	25	M12	45	90	145	50
FD32FB	66.7	78	20	105	154	56	30	42	G3/4	M27x2	15	30	M14	50	105	145	52

Model	L2	L3	L4	L5	L6	L7	L8	T1	Weight	O-ring (7)	valve fixing screw
FD12FB	23.8	105	141.5	65	162	38	78	15	9kg	25x3.5	4 pcs M10x100
FD16FB	23.8	105	141.5	65	162	38	78	15	9kg	25x3.5	4 pcs M10x100
FD25FB	27.8	148	198	75	225	50	105	18	20kg	32.92x3.53	4 pcs M12x120
FD32FB	31.8	155	215	94	240	50	115	21	28kg	37.7x3.53	4 pcs M14x140