

Explosion-proof Solenoid Operated Poppet Valve

Model: G-M-SEW6...3XJ



- ◆ Size 6
- ◆ Maximum working pressure 420/630 bar
- ◆ Maximum working flow 25 L/min

Contents

Function description, sectional drawing	02-03
Models and specifications	04
Technical parameters	05
Characteristic curve	06
Characteristic limit	07
Component size	08-09
Application examples	10

Features

- Steel ball directional valve operated by explosion-proof solenoid
- Switching smoothly even in high-pressure state long periods
- Closed port without leakage

Any part of this brochure can not be reproduced, edited, copied and disseminated electronically in any way without authorization of Jiayite Hydraulics company. As the product is in constant development and innovation, the information in this brochure is not specific to the special conditions or applicability of a specific industry, thus Jiayite Hydraulics company is not responsible for any incomplete or inaccurate description generated.



Function description, sectional drawing

2/2-way, 3/-way poppet directional valve

The G-M-SEW directional valve is explosion-proof solenoid operated poppet valve. It is used to control the opening, closing and direction of oil.

The valve is mainly composed of valve body (1), solenoid (2), hardened valve system (3) and ball (4) as the closing element. Basic function:

In the initial position, the spool (4) is pushed against the valve seat by the spring (9) and by the solenoid (2) when in the switching position. The force of the solenoid (2) acts on the actuating push rod which is sealed on both sides through the lever (6) and the ball (7). The chamber between the two sealing elements is connected to the port P. Therefore, the valve system (3) is pressure compensated based on the actuating force (solenoid or spring). In this way, the valve can be used up to 630bar.

Note:

The 3/2-way poppet directional valve has negative cover function. Therefore, port T must be always connected. That means the ports P-A-T are connected with each other during the switching process (from the starting of the opening of one valve seat to the closing of the other valve seat). But this process is completed in a very short time, so it is irrelevant in almost all applications. It must ensure that the maximum flow does not exceed the performance limit of the valve. If necessary, the cartridge throttle can be installed to limit the flow.

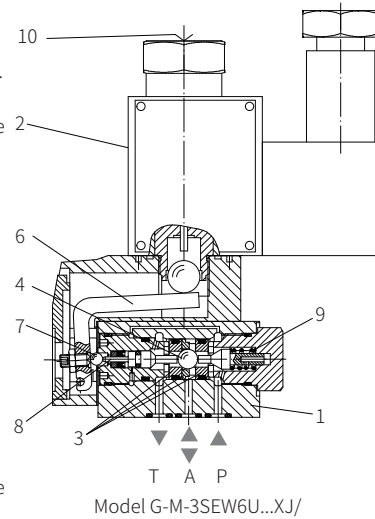

Model G-M-3SEW6U...XJ/

2/2-way directional seat valve		3/2-way directional seat valve	
Symbol "P"		Symbol "U"	
Initial position	P and T connected	Initial position	P and A connected, T blocked
Switching position	P blocked	Switching position	P blocked, A and T connected
Symbol "N"		Symbol "C"	
Initial position	P blocked	Initial position	P blocked, A and T connected
Switching position	P and T connected	Switching position	P and A connected, T blocked

Function description, sectional drawing

4/2-way solenoid directional seat valve G-M-4SEW6

Initial position: When the solenoid is not energized, the force of the spring (6) holds the ball spool (12) on the left valve seat (8). The port P is connected to A. The pump pressure oil acts on the large area of the control piston (15) through the control line from port A. The steel ball (13) is pushed to the other side of the valve seat (14), so P is connected to A and B to T.

Switching position: After the solenoid is powered on, the oil port A and T are connected. In addition, the control line from the oil port A acts on the large area of the control piston (15) to unload to the tank. The pressure oil provided from the oil port P pushes the steel ball (13) to the valve seat (14). At this time, the oil port P is connected to B.

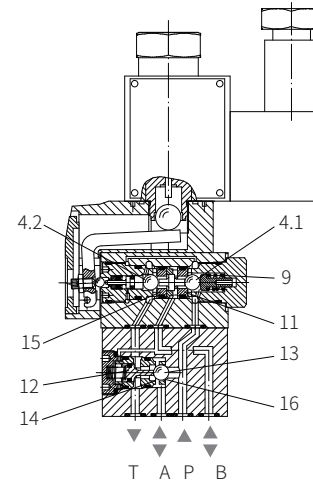

Model G-M-4SEW6Y...3XJ/

The seat valve with plus-1 plate as below:

Symbol "D"

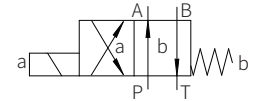

Symbol "Y"

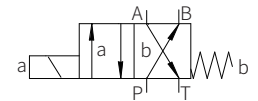

Cartridge throttle

Due to the working conditions limitations, it may occur that the flow exceeds the performance limit of the valve during the switching process, then the use of a throttle is required.

Example:

- Accumulator operation
- Used as a pilot valve with internal pilot oil supply

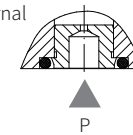

3/2-way poppet valve

The throttle is inserted into the port P of the directional valve.

4/2-way poppet valve

The throttle is inserted into the oil port P of the plus-1 plate.

Cartridge check valve

The cartridge check valve allows free flow from P to A and leak-free closure from A to P.

3/2-way poppet valve

The cartridge check valve is inserted into the oil port P of the directional valve.

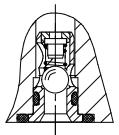

4/2-way poppet valve

The cartridge check valve is inserted into port P of the plus-1 plate.

Models and specifications

explosion -proof class I =G1 explosion -proof class II =G2				
working oil port 2 =2 working oil port 3 =3 working oil port 4 =4				
poppet valve				
size 6				=6
working port	2	3	4	
	●	-	-	=P
	●	-	-	=N
	-	●	-	=U
	-	●	-	=C
	-	-	●	=D
	-	-	●	=Y
	●=available			
30 to 39 series (30 to 39 series installation and connection size unchanged)				=3X
Rekith				=J
working pressure to 420 bar (fixing screw M5)				=420
Working pressure to 630 bar (fixing screw M6)				=630
solenoid with detachable coil (air-gap)				=M

more information in text

sealing material
No code= NBR seals
V= FKM seals
(consult for other seals)

No code= without cartridge check valve and cartridge throttle
P= with cartridge check valve
B12= throttle Ø1.2mm
B15= throttle Ø1.5mm
B18= throttle Ø1.8mm
B20= throttle Ø2.0mm
B22= throttle Ø2.2mm

N9= with hidden emergency operation

G24= 24 V DC

Note: G1 explosion-proof grade EXD I
G2 explosion-proof grade EXD II CT4

01

Technical parameters

Overview	
Environment temperature range	°C -30 to +50 (NBR seal) -20 to +50 (FKM seal)
Weight	2/2-way valve kg 2.7
	3/2-way valve kg 2.7
	4/2-way valve kg 3.5
Hydraulic	
Maximum working pressure	bar See characteristic limit
Maximum flow	L/min 25
Hydraulic oil	Mineral oil (HL, HLP) ¹⁾ in accordance with DIN 51524; Fast living organisms degraded oil according to VDMA 24568; HETG (Rapeseed oil) ¹⁾ ; HEPG (Polyethyleneglycol) ²⁾ ; HEES (Synthetic Fats) ²⁾
Oil temperature range	°C -30 to +80 (NBR seal) -20 to +80 (FKM seal)
Viscosity range	mm ² /s 2.8 to 500
Cleanliness of oil	The maximum allowable pollution level of oil is ISO4406 Class 20/18/15
Electrical	
Voltage type	DC
Available voltage	V 24
Allowable voltage tolerance (nominal voltage) %	±10
Power consumption	W 3
Continuous power on time	% 100
Switching time according to ISO 6403	See table below
Switching frequency	times/hour 15000
Maximum coil temperature	°C 150

The oil must meet the cleanliness degree requested by the components in the hydraulic system. Effective oil filtration can prevent failure and increase the service life of the components.

Switching time tms (installation position: solenoid installed horizontally)

Pressure P bar	Flow q _v L/min	DC Solenoid					
		Functional symbols U, C, D, Y					
		t _{on} No tank pressure			t _{off}		
		U	C	D	Y	U/C	D/Y
140	25	25	30	25	30	10	10
280	25	25	30	25	30	10	10
320	25	25	35	25	35	10	10
420	25	25	35	25	35	10	10
500	25	25	40	25	40	10	10
600	25	25	40	25	40	10	10

Electrical protective conductor (PE ⚡) must be connected properly as rules

01

Characteristic curve

(Measured when using HLP46, $\vartheta_{oil}=40^{\circ}\text{C} \pm 5^{\circ}\text{C}$)

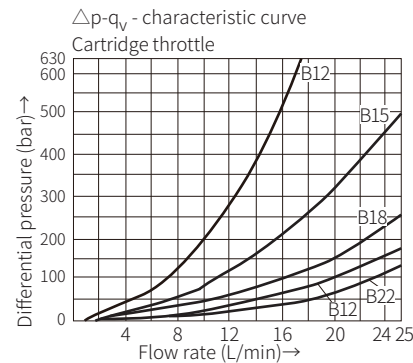
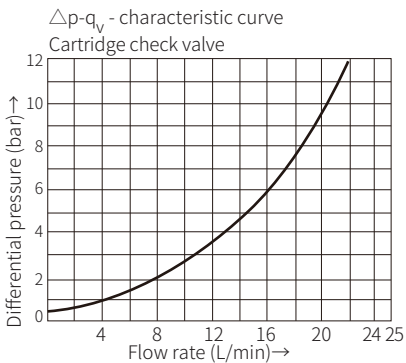
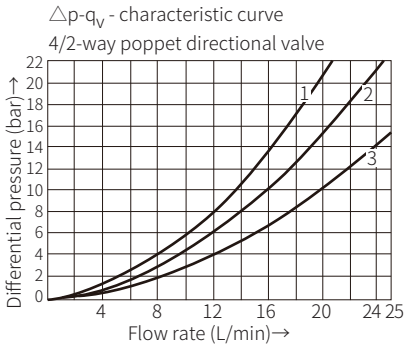
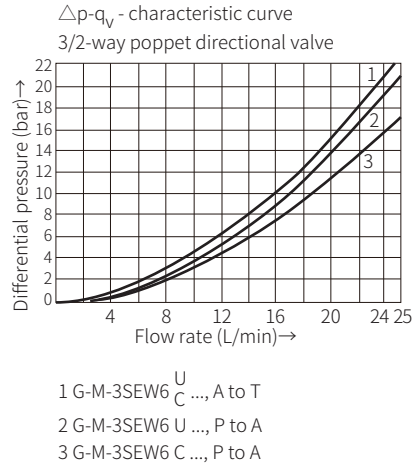
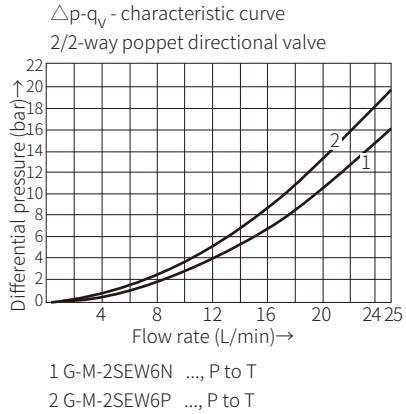

Characteristic limit

	Functional symbol	comment	Working pressure bar				Flow L/min
			P	A	B	T	
Two-way circuit	“P” 	Oil port pressure $P \geq T$	420/630			100	25
	“N” 		420/630			100	25
Three-way circuit	“U” 	Oil port pressure $P \geq A \geq T$	420/630	420/630		100	25
	“C” 		420/630	420/630		100	25
Two way circuit (Only for unloading function)	“U” 	Pressure must be maintained in port A before switching from the original position to the switching position. Oil port pressure $A \geq T$		420/630		100	25
	“C” 	Oil port pressure $A \geq T$		420/630		100	25
Four-way circuit (flow only in the direction of arrow)	“D” 	Single poppet valve (symbol “U”) with plus-1 plate $P \geq A \geq B \geq T$	420/630	420/630	420/630	100	25
	“Y” 	Double poppet valve (symbol “C”) with plus-1 plate $P \geq A \geq B \geq T$	420/630	420/630	420/630	100	25

Note:

- In order to operate the valve safely or keep it in the switching position, the oil port pressure $P \geq A \geq T$ (based on the structure).
 - The ports P, A and T (3/2-way valve), and ports P, A, B and T (4/2-way valve) are configured according to their functions and must not be blocked or used in other ways. Liquid flow is only allowed in the direction of the arrow.
 - When using the plus-1 plate (4/2-way valve), the following data must be met: $P_{min}=8\text{bar}$; $Q>3\text{ L/min}$
 - The specified maximum flow should not be exceeded.
- The characteristic limit is measured when the solenoid is at operating temperature, at 10% below the standard voltage and without tank preloading.

Component size

Size unit: mm

2/2 and 3/2-way poppet directional valve

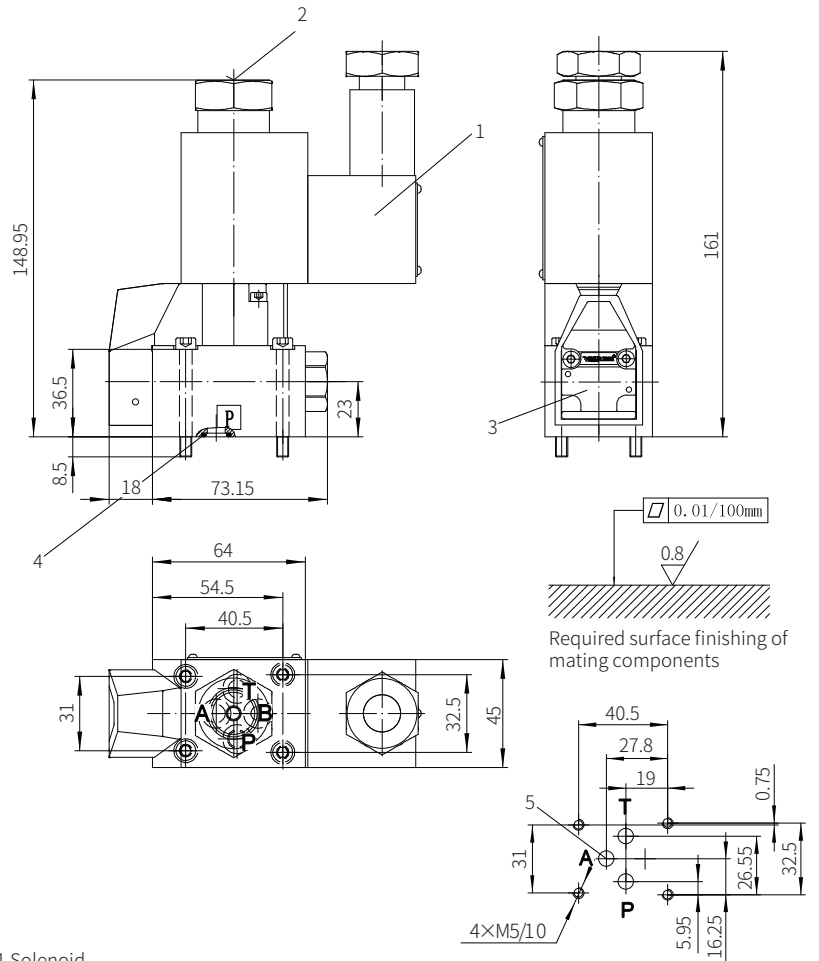

- 1 Solenoid
 2 Hidden emergency button
 3 Name plate
 4 O-ring 10x2(for oil port P)
 O-ring 9.25x1.78(for oil ports B, A, T) 420bar type
 O-ring 9.25x1.78(for oil ports P, B, A, T) 630bar type
 5 Port A and B are blind holes for 2/2-way valve
 Port B is a blind hole for 3/2-way valve

Valve fixing screw
 Version 420 bar
 M5x45-10.9 grade GB/T70.1-2000
 Tightening torque $M_A=7.8\text{Nm}$
 Version 630 bar
 M6x45-10.9 grade GB/T70.1-2000
 Tightening torque $M_A=13.7\text{Nm}$

Component size

Size unit: mm

4/2-way poppet directional valve

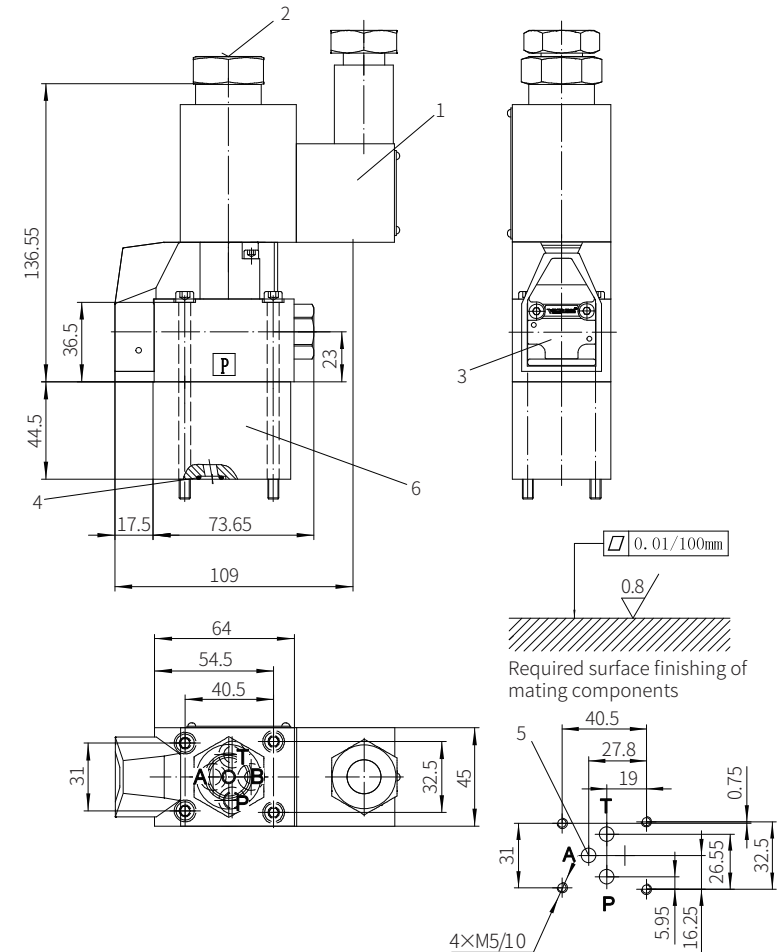

- 1 Solenoid
 2 Hidden emergency button
 3 Name plate
 4 O-ring 10x2(for oil port P)
 O-ring 9.25x1.78(for oil ports B, A, T)
 Port B is a blind hole for 3/2-way valve
 6 Plus-1 plate

Valve fixing screw
 Version 420 bar
 M5x90-10.9 grade GB/T70.1-2000
 Tightening torque $M_A=7.8\text{Nm}$
 Version 630 bar
 M6x90-10.9 grade GB/T70.1-2000
 Tightening torque $M_A=13.7\text{Nm}$

Application examples

These examples only indicate some applications of the poppet valve but not include all functions.

<p>Symbol C</p>	<p>2/2-way circuit with two poppet valves and check valve at port A The check valve must be installed on the pipeline. Initial position: the flow is blocked and the maximum pressure is allowed. Due to the check valve at port A, the pressure is held in the actuator even when the pump is turned off. Switching position: The fluid flows freely and the maximum pressure is allowed. The oil is drained via port T. The only oil leakage occurring is that the oil flows to port T during the switching process.</p>	<p>Symbol U</p>	<p>3/2-way circuit with a single poppet valve Initial position: Lifting The maintenance of position only depends on the stroke limit and the pressure at port P. Switching position: Descending</p>
<p>Symbol U</p>	<p>2/2-way circuit with a single poppet valve and check valve at port A The check valve must be installed on the pipeline. Initial position: The fluid flows freely and the maximum pressure is allowed. Due to the check valve at port A, the pressure is held in the actuator even when the pump is turned off. Switching position: The flow blocked and the maximum pressure is allowed. The oil is drained via port T. The only oil leakage occurring is that the oil flows to port T during the switching process.</p>	<p>Symbol C</p>	<p>3/2-way circuit with two poppet valves and cartridge check valve at port A The check valve is installed at port P of the 3/2-way directional poppet valve. Initial position: Descending Switch position: Lifting The load can be held in any position when the pump is turned off and the solenoid is energized.</p>
<p>Symbol C</p>	<p>3/2-way circuit with two poppet valves Initial position: Descending Switch position: Lifting The maintenance of position only depends on the stroke limit and the pressure at port P.</p>	<p>Symbol U</p>	<p>3/2-way circuit with a single poppet valve and cartridge check valve at port P The check valve is installed at port P of the 3/2-way popper valve. Initial position: Lifting The load can be held in any position when the pump is turned off. Switching position: Descending</p>
<p>Symbol C</p>	<p>4/3-way (4/4-way) circuit with two poppet valves V1 and V2 in the initial position: both ends of the cylinder are connected to the oil tank port. V2 in the switching position: the piston moves to the left. V1 in the switching position: the piston moves to the right. V1 and V2 in the switching position: both ends of the cylinder are connected to the pump port. The fast movement is possible when a single rod cylinder with an area ratio of 2:1 is used. Attention! When using single rod cylinders, the performance limit (double flow) of the valve and the maximum permissible working pressure (overpressure) must be taken into account!</p>		
<p>Symbol U</p>	<p>4/3-way (4/4-way) circuit with two poppet valves and cartridge check valve at port P of the 3/2-way poppet valve V1 and V2 in the initial position: the piston is locked externally to prevent oil flow. V2 in the switching position: the piston moves to the right. V1 in the switching position: the piston moves to the left. V1 and V2 in the switching position: both ends of the cylinder are connected to the tank port. Attention! When using single rod cylinders, the performance limit (double flow) of the valve and the maximum allowable working pressure (overpressure) must be taken into account!</p>		

Explosion-proof Solenoid Operated Poppet Valve

Model: G-M-SEW10...1XJ



- ◆ Size 10
- ◆ Maximum working pressure 420/630 bar
- ◆ Maximum working flow 40 L/min

Contents

Function description, sectional drawing	02-03
Models and specifications	04
Technical parameters	05
Characteristic curve	06
Characteristic limit	06
Component size	07-09
Application examples	10

Features

- Closed port without leakage
- Switching flexibility even in high-pressure state long periods
- Air-gap DC solenoid with detachable coil
- Solenoid coil can be rotated 90°