

## Restrictive Valve and Restrictive Check Valve

Model: MG/MK...1XJ



- ◆ Size 6 to 30
- ◆ Maximum working pressure 350 bar
- ◆ Maximum working flow 400 L/min

### Contents

Function description, sectional drawing	02
Models and specifications	02
Functional symbols	03
Technical parameters	03
Characteristic curve	04
Component size	05

### Features

- Suitable for direct in-line mounting
- Performance depends on pressure and viscosity

Any part of this brochure can not be reproduced, edited, copied and disseminated electronically in any way without authorization of Jiayite Hydraulics company. As the product is in constant development and innovation, the information in this brochure is not specific to the special conditions or applicability of a specific industry, thus Jiayite Hydraulics company is not responsible for any incomplete or inaccurate description generated.



## Function description, sectional drawing

The MG and MK valve is a restrictive valve and restrictive check valve which is related to oil pressure and viscosity.

### Model MG (restrictive valve)

This valve throttles in both flow directions. The hydraulic oil flows through side hole (3) to the throttling orifice (4) which is formed by valve body (2) and adjusting sleeve (1). The cross-section of the throttling orifice (4) can be adjusted infinitely by rotating the adjusting sleeve (1).

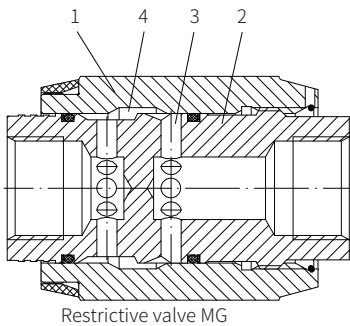

Restrictive valve MG

### Model MK (restrictive check valve)

When the fluid flows through the valve in throttling direction, the pressure oil and spring (6) presses the spool (5) onto the valve seat, then the connection is blocked. The hydraulic oil flows through the side hole (3) to the throttling orifice (4) which is formed by valve body (2) and adjusting sleeve (1).

In the opposite direction, the pressure acts on the face of the spool (5) to open the check valve and allow the fluid to flow through the check valve without throttling. At the same time, parts of the hydraulic oil flows through the annular groove to achieve the desired self-cleaning effect.

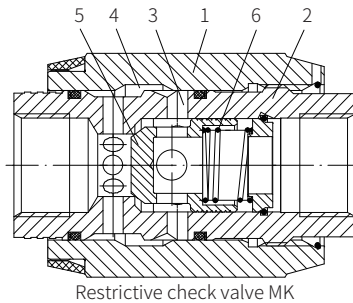

Restrictive check valve MK

## Models and specifications

		G	1X	J	*	
restrictive valve	=MG					
restrictive check valve	=MK					
size 6	=6					
size 8	=8					
size 10	=10					
size 15	=15					
size 20	=20					
size 25	=25					
size 30	=30					
threaded connection	=G					
				J=		Rekith
						1X= 10 to 19 series (10 to 19 series installation and connection size unchanged)
						more information in text
						sealing material
						No code= NBR seals
						V= FKM seals
						(consult for other seals)
						No code= G thread
						2= metric thread

## Functional symbols

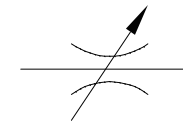

Model MG

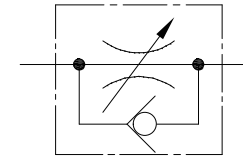

Model MK

## Technical parameters

Overview								
Installation position	Optional							
Environment temperature range	°C	-20 to +50						
Weight		6	8	10	15	20	25	30
	kg	0.3	0.4	0.7	1.1	1.9	3.2	4.1
Hydraulic								
Maximum working pressure	bar	315						
Cracking pressure MK model	bar	0.5						
Maximum flow	L/min	400						
Oil fluid	Mineral oil (HL, HLP) <sup>1)</sup> in accordance with DIN 51524; Fast living organisms Degraded oil according to VDMA 24568; HETG (Rapeseed oil) <sup>1)</sup> ; HEPG (Polyethyleneglycol) <sup>2)</sup> ; HEES (Synthetic Fats) <sup>2)</sup>							
Oil temperature range	°C	-30 to +80 (NBR seal), -20 to +80 (FKM seal)						
Viscosity range	mm <sup>2</sup> /s	10 to 800						
Cleanliness of oil	The maximum allowable pollution level of oil is ISO4406 class 20 / 18 / 15							

1) The oil must meet the cleanliness degree requested by the components in the hydraulic system. Effective oil filtration can prevent failure and increase the service life of the components.

**Characteristic curve**

(Measured when using HLP 46,  $t_{oil} = 40^{\circ}\text{C} \pm 5^{\circ}\text{C}$ )

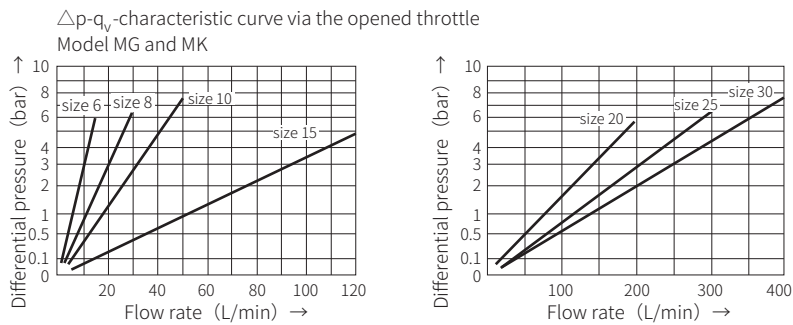
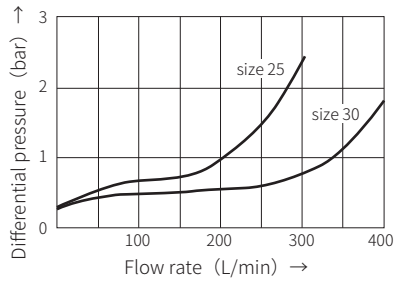
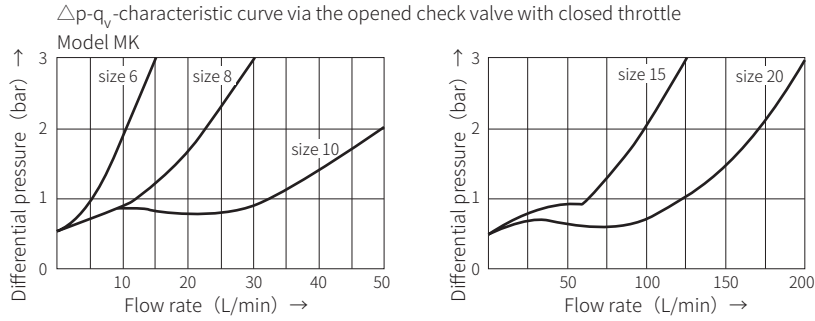

**Component size**

Size unit: mm

Model MK and MG

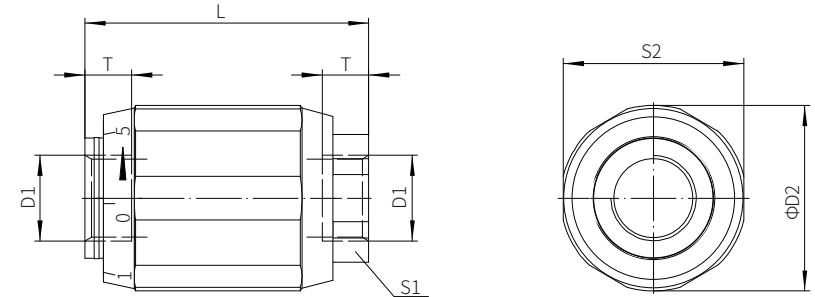

Size	D1		D2	L1	S1	S2	T1
	G	Metric					
6	G1/4	M14×1.5	34	65	22	32	12
8	G3/8	M18×1.5	38	65	24	36	12
10	G1/2	M22×1.5	48	80	30	46	14
15	G3/4	M27×2	58	100	41	55	16
20	G1	M33×2	72	110	46	70	18
25	G1 1/4	M42×2	87	130	55	85	20
30	G1 1/2	M48×2	93	150	60	90	22