

## Component size

Size unit: mm

## Dimension of additional devices for model WEH32

The installation range of the stroke adjustment is 15mm. The stroke limiter is used to adjust the stroke of the main spool. Loosen the lock nut and rotate the adjusting rod clockwise, the stroke of the main spool will be shortened (the adjustment must be carried out without pressure in the control chamber)

1 turn = 1.5mm stroke

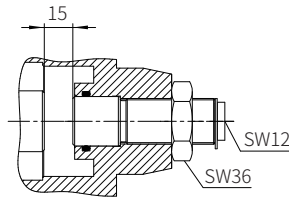

Stroke adjustment installed on the ends A and B of the main valve.../10

Stroke adjustment installed on the end A of the main valve.../11

Stroke adjustment installed on the end B of the main valve.../12

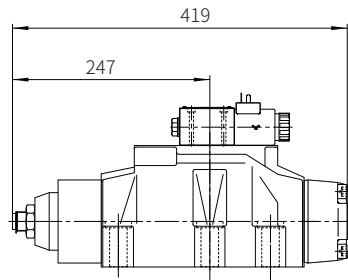
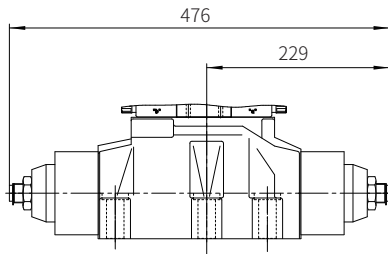
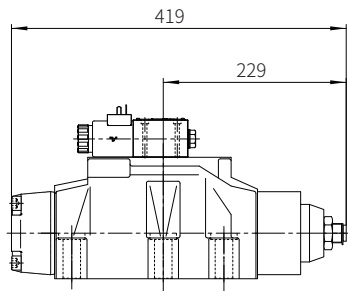
Stroke adjustment installed on the end A of the main valve.../11  
(2-position valve, symbols C, D, K, Z)Stroke adjustment installed on the end B of the main valve.../12  
(2-position valve, symbol Y)

## Hydraulic or Electro-hydraulic Directional Valve

Model: WEH/WH...4X/6X/7XJ



- ◆ Size 10~32
- ◆ Maximum working pressure 350 bar
- ◆ Maximum working flow 1100 L/min

## Contents

Function description, sectional drawing	02 - 04
Models and specifications	05
Functional symbols	06-08
Technical parameters	09-10
Characteristic curve	11-15
Characteristic limit	11-15
Switching time adjustment, pressure reducing valve and pre-load valve	16
Component size	17-25

## Features

- Mainly used to control the opening, closing and direction of liquid flow
- Electro-hydraulic operation (WEH)
- Hydraulic operation (WH)
- Subplate mounting
- The mounting surface according to DIN24340 form A and ISO4401
- Spring or hydraulic centered
- Spring or hydraulic return to initial position
- Wet-pin DC or AC solenoid
- Optional manual emergency operation
- Individual or central electrical connection
- Optional switching time adjustment
- Optional pre-load valve in port P of the main valve
- Auxiliary component, optional
  - Stroke adjustment of main spool
  - Stroke adjustment or end position sensor
  - Inductive or mechanical limit switch (proximity type) of the main spool

## Function description, sectional drawing

**Directional valve model WEH**

The WEH directional valve is a directional spool valve with electro-hydraulic operation. It is used to control the opening, closing and direction of the liquid flow. The valve mainly consists of valve body (1), main control spool (2), main valve with one or two reset springs (3.1) and (3.2), pilot valve (4) with one or two solenoids "a" (5.1) and "b" (5.2). The main control spool is held in the neutral or initial position by the springs or pressure. For the valve with spring-centered, the two spring chambers (6) and (8) are connected to the oil tank through the pilot valve in the initial position. The pilot valve (4) is supplied with oil through the control line (7). The control oil can be supplied internally or externally (externally via port X). The main control spool (2) is hydraulically operated by the pilot valve (4). Due to the operating of the pilot valve on one end of the main control spool, the spool moves to the operation position, then the valve opens in the operation direction and the fluid flows from P to A and B to T or P to B and A to T. The control oil can be drained internally or externally. An optional manual emergency operation (9) can move the control spool (10) in the pilot valve (4) when the solenoid is not energized.

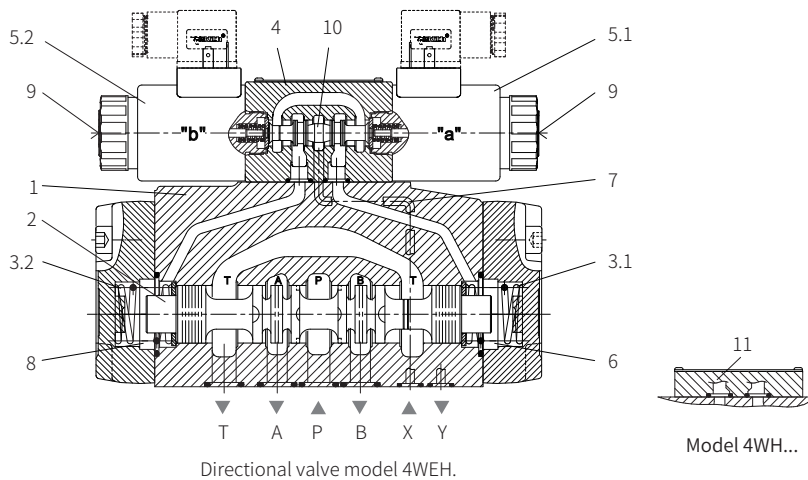
**Directional valve model WH**

The WH directional valve is a hydraulically operated directional spool valve. It is used to control the opening, closing and direction of liquid flow. The valve mainly consists of valve body (1), main control spool (2), one or two reset springs (3.1) and (3.2) with spring centered or spring return functions, and control cover (11). The main control spool is operated by hydraulic directly. The spool is held in the neutral or initial position by springs or hydraulic pressure. The control oil is supplied and drained externally. For the 4/3-way valve with spool spring centered, the main control spool (2) is held in the neutral position by two centered springs. The two spring chambers (6, 8) are connected to the oil ports X and Y through the control cover (11). When one end of the main control spool (2) is pressurized, the spool moves to the working position, thereby connecting the corresponding oil circuit.

## Function description, sectional drawing

**4/3-way directional valve with hydraulic centered of main valve, model WEH..H/**

In this structure, the pressure oil acts on both end surfaces of the main control spool (2). The centering sleeve (10) locates the main control spool (2) and keeps it in the middle position. If one end of the main control spool (2) is unloaded, the main control spool (2) moves to the working position under the pressure from the other end, thereby changing the direction of the oil flow. The unloaded control spool face displaces the returning pilot oil into port Y externally through the pilot valve (4). The oil is drained internal from port L to the tank directly.

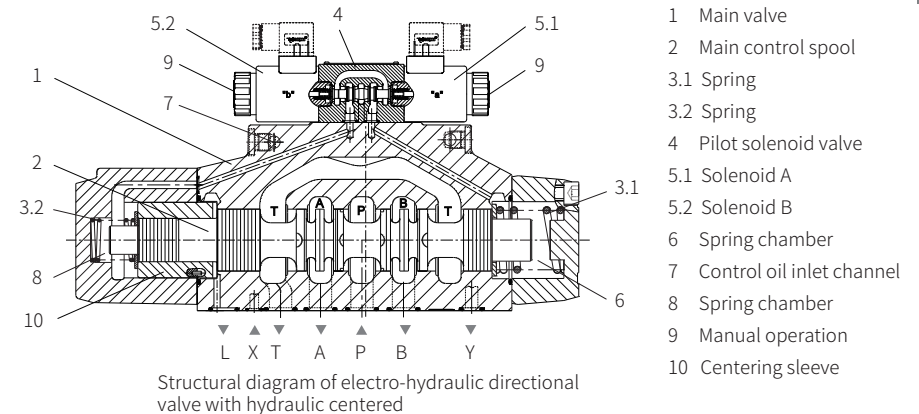
**Pilot oil supply****● Model WEH10**

◆ Conversion between internal supply and external supply:

The channel P on the top of the main valve body with M6 screw (3) is external supply, and is internal supply when M6 screw (3) dismounted.

◆ Conversion between internal drain and external drain:

Removing the plug (1) and installing M6 screw (2) is external drain, dismounting M6 screw (2) is internal drain.

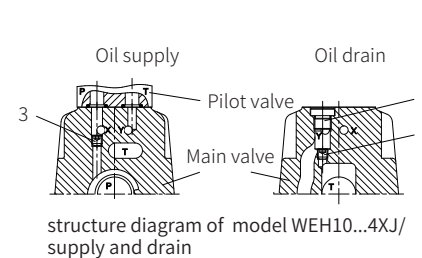
**● Model WEH16**

◆ Conversion between internal supply and external supply:

The channel P on the bottom of the main valve with M6 screw (8) is external supply, and is internal supply when M6 screw (8) dismounted.

◆ Conversion between internal drain and external drain:

The channel T on the top of the main valve with M6 screw (7) is external drain, and is internal drain when M6 screw (7) dismounted.

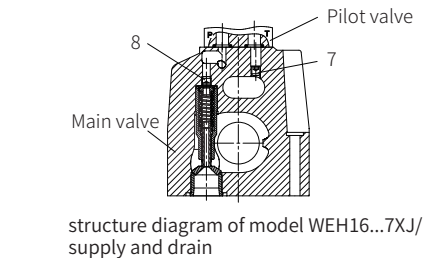



Functional symbols

Detailed and simplified symbols for 3-position directional valves

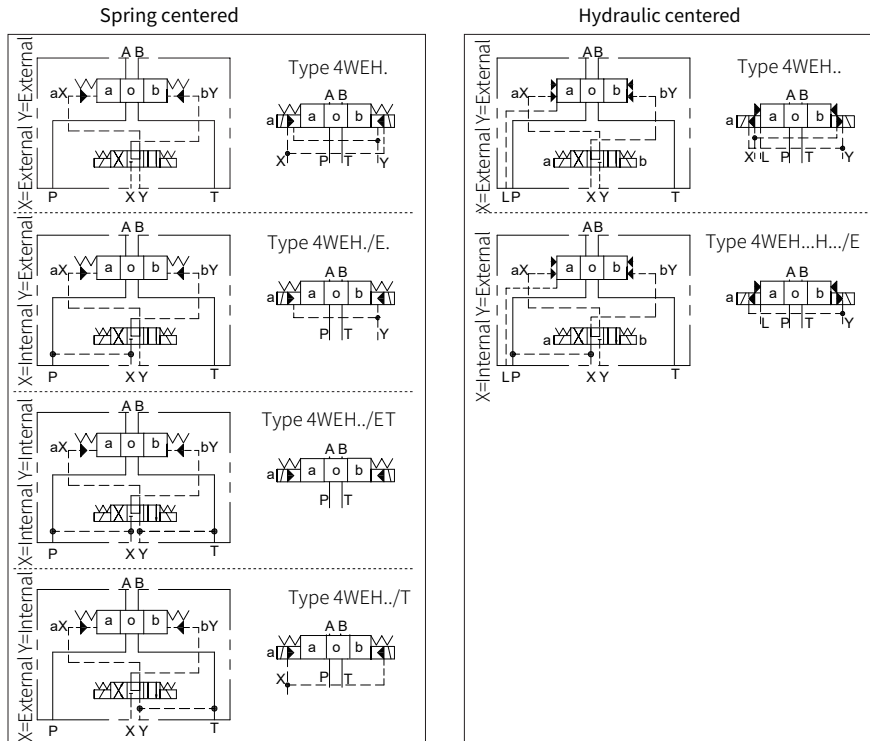

Spring return valves  
(the solenoid at end A or B of the 2-position valve derived from the 3-position valve)

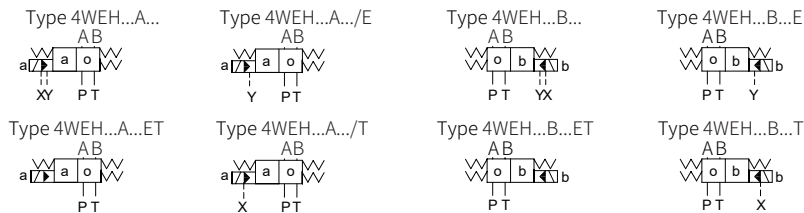

Hydraulic return valves  
(the solenoid at end A or B of the 2-position valve derived from the 3-position valve)

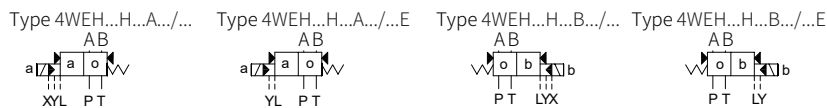

01

Functional symbols

Functional symbols of 3-position valves

3-position valve

3-position valve model	Functional symbol	Transition function
4WEH...E.../... E		
4WEH...F.../... F		
4WEH...G.../... G		
4WEH...H.../... H		
4WEH...J.../... J		
4WEH...L.../... L		
4WEH...M.../... M		
4WEH...P.../... P		
4WEH...Q.../... Q		
4WEH...R.../... R		
4WEH...S.../... S		
4WEH...T.../... T		
4WEH...U.../... U		
4WEH...V.../... V		
4WEH...W.../... W		

2-position valve derived from 3-position valve

2-position valve model (Solenoid at end A)	Functional symbol	2-position valve model (Solenoid at end B)	Functional symbol
4WEH...EA.../... (Solenoid at end A)		4WEH...EB.../... (Solenoid at end B)	
4WEH...FA.../... (Solenoid at end A)		4WEH...FB.../... (Solenoid at end B)	
4WEH...GA.../... (Solenoid at end A)		4WEH...GB.../... (Solenoid at end B)	
4WEH...HA.../... (Solenoid at end A)		4WEH...HB.../... (Solenoid at end B)	
4WEH...JA.../... (Solenoid at end A)		4WEH...JB.../... (Solenoid at end B)	
4WEH...LA.../... (Solenoid at end A)		4WEH...LB.../... (Solenoid at end B)	
4WEH...MA.../... (Solenoid at end A)		4WEH...MB.../... (Solenoid at end B)	
4WEH...PA.../... (Solenoid at end A)		4WEH...PB.../... (Solenoid at end B)	
4WEH...QA.../... (Solenoid at end A)		4WEH...QB.../... (Solenoid at end B)	
4WEH...RA.../... (Solenoid at end A)		4WEH...RB.../... (Solenoid at end B)	
4WEH...SA.../... (Solenoid at end A)		4WEH...SB.../... (Solenoid at end B)	
4WEH...TA.../... (Solenoid at end A)		4WEH...TB.../... (Solenoid at end B)	
4WEH...UA.../... (Solenoid at end A)		4WEH...UB.../... (Solenoid at end B)	
4WEH...VA.../... (Solenoid at end A)		4WEH...VB.../... (Solenoid at end B)	
4WEH...WA.../... (Solenoid at end A)		4WEH...WB.../... (Solenoid at end B)	

01

Functional symbols

Detailed and simplified symbols for 2-position directional valves

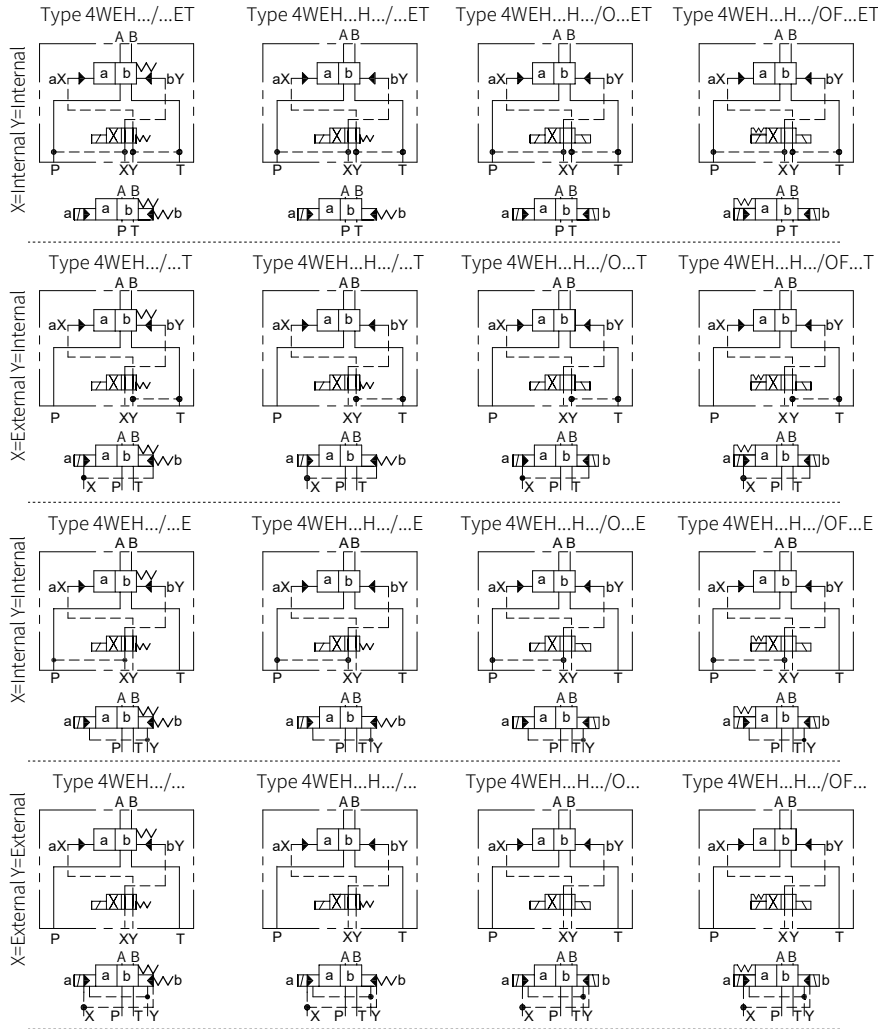

Function symbols of 2-position valves

Spool valve function:	C	D	K	Z	Y
Spool valve function symbol:					
Transition function:					

Technical parameters

Size	10	16	22	25	32			
Maximum working pressure								
Oil ports P, A, B (MPa)	35	35	35	35	35			
Oil port T	External Y port pilot oil drain (MPa)	31.5 <sup>9)</sup>	25	25	25			
	Internal Y port pilot oil drain (MPa)				21 DC	16 AC		
Oil port Y	-DC solenoid (MPa)				21 DC			
External pilot oil drain	-AC solenoid (MPa)				16 AC			
	For 4WH type (MPa)	25 (size 10, 16, 25, 32)		21 (size 22)				
Maximum pilot pressure (For high pilot pressure, a pressure reducing valve is required) (MPa)	25 (size 10, 16, 25, 32)		21 (size 22)					
Minimum pilot pressure	H-4W...							
-Pilot oil supply X external								
-Pilot oil supply X internal (Not for spool C, F, G, H, P, T, V, Z, S <sup>2)</sup> )								
Spring centered 3-position valve (MPa)	1.0	1.4	1.25	1.3	0.85			
Pressure centered 3-position valve (MPa)	-	1.4	1.05	1.8	0.85			
Spring centered 2-position valve (MPa)	1.0	1.4	-	1.3	1.0			
Pressure centered 2-position valve (MPa)	0.7	1.4	1.4	0.8	0.5			
Pilot oil supply X internal (for spool C, F, G, H, P, T, V, Z, S <sup>2)</sup> )	0.45 <sup>3)</sup>	0.45 <sup>4)</sup>	0.45 <sup>4)</sup>	0.45 <sup>4)</sup>	0.45 <sup>4)</sup>			
<p>1) In a 3-position valve, pressure centered only possible if: Ppilot ≥ 2xPtank + Ppilot min.</p> <p>2) Spool S only for size 16.</p> <p>3) For the spools C, F, G, H, P, T, V, Z, the internal pilot oil supply is only possible if the flow from P to T in the central position (for 3-position valve) or when the valve moves through the central position (for 2-position valve) is large enough to ensure the pressure differential as 0.65MPa from P to T.</p> <p>4) For the spools C, F, G, H, P, T, V, Z, S-via the pre-load valve or correspondingly large flow.</p> <p>5) 28MPa for model 4WEH10..., 31.5MPa for model H-4WEH10... H-4WEH10... type is 31.5MPa</p>								
Hydraulic oil	Mineral hydraulic oil or phosphate ester hydraulic oil							
Temperature range (°C)	-30 to +80 (NBR seal)		-20~+80 (FKM seal)					
Viscosity range (mm <sup>2</sup> /s)	2.8 to 500							
Cleanliness of oil	The maximum allowable pollution level of oil is NAS1638 Class 9, so we recommend a filter with the minimum filtration accuracy β10 ≥ 75							
Pilot oil volume during switching process								
3-position valve spring centered (cm <sup>3</sup> )	2.04	5.72	7.64	14.2	29.4			
2-position valve (cm <sup>3</sup> )	4.08	11.45	15.28	28.4	58.8			
3-position valve hydraulic centered (cm <sup>3</sup> )	-	WH	WEH	-	WH	WEH	WH	WEH
from neutral position to position "a" (cm <sup>3</sup> )	-	2.83	2.83	-	7.15	7.15	14.4	14.4
From position "a" to neutral position (cm <sup>3</sup> )	-	5.72	5.72	-	14.18	7.0	29.4	15.1
From neutral position to position "b" (cm <sup>3</sup> )	-	5.72	5.72	-	14.18	14.15	29.4	29.4
from position "b" to neutral position (cm <sup>3</sup> )	-	8.55	8.55	-	19.88	5.73	43.8	14.4
Pilot oil flow for shortest switching time (L/min)	about 35	about 35	about 35	about 35	about 45			
Weight	Valve with one solenoid (kg)	about 6.4	about 8.5	about 11.5	about 17.6	about 40.5		
	Valve with two solenoid, spring centered (kg)	about 6.8	about 8.9	about 11.9	about 18.0	about 41.0		
	Valve with two solenoid, hydraulic centered (kg)	about 6.8	about 8.9	about 11.9	about 19.0	about 41.0		
	Valve with hydraulic control (kg)	about 5.5	about 7.3	about 10.5	about 16.5	about 39.5		
	Switching time adjustment (kg)	about 0.8						
Pressure reducing valve (kg)	about 0.4							
Installation position	Optional, except for the hydraulic return valve C, D, K, Z, Y installed horizontal							

Technical parameters

Switching time (refers to the time from the solenoid closing to the main valve fully opening.)													
Size 10	Switching time for valve from neutral position to operating position (for DC (=) and AC (~) operation)												
	at pilot pressure	(MPa)		~7=		~14=		~21=		~25=			
	3-position valve	(ms)	30	65	25	60	20	55	15	50			
	2-position valve	(ms)	35	80	30	75	25	70	20	65			
	Switching time for valve from operating position to neutral position (ms)												
3-position valve	(ms)	30											
2-position valve	(ms)	35	40	30	75	25	30	20	25				
Size 16	Switching time for valve from neutral position to operating position (for DC (=) and AC (~) operation)												
	at pilot pressure	(MPa)		~7=		~15=		~25=					
	3-position valve-spring centered	(ms)	25...30	40	25...30	40	25...30	40					
	2-position valve	(ms)	30...35	55	30...35	55	30...35	55					
	3-position valve Solenoid operated - hydraulic centered	(ms)	a	b	a	b	a	b	a	b	a	b	
			30	30	40	40	30	30	40	40	30	30	
			35	40	30	30	40	40	30	30	35	40	
Switching time for valve from operating position to static position													
3-position valve	(ms)	20 to 35 for ~; 30 for =											
2-position valve	(ms)	30...50	45	30...50	45	30...50	45						
3-position valve - hydraulic centered	(ms)	From-	a	b	a	b	a	b	a	b	a	b	
		20...35	20	20...55	20	20...35	20						
Size 25	Switching time for valve from neutral position to operating position (for DC (=) and AC (~) operation)												
	at pilot pressure	(MPa)		~7=		~14=		~21=		~25=			
	3-position valve-spring centered	(ms)	50	85	40	75	35	70	30	65			
	2-position valve	(ms)	120	160	100	130	85	120	70	105			
	3-position valve Solenoid operated - hydraulic centered	(ms)	a	b	a	b	a	b	a	b	a	b	
			20	35	55	65	30	35	55	65	25	30	
			50	60	25	30	50	60	25	30	50	60	
	Switching time for valve from operating position to static position												
	3-position valve	(ms)	40 to 55 for ~; 40 for =										
	2-position valve	(ms)	120	125	85	100	85	90	75	80			
3-position valve - hydraulic centered	(ms)	From-	a	b	a	b	a	b	a	b	a	b	
		30...50	30	35	30...50	30	35	30...50	30	35	30...50	30	35
Size 32	Switching time for valve from neutral position to operating position (for DC (=) and AC (~) operation)												
	at pilot pressure	(MPa)		~5=		~15=		~25=					
	3-position valve-spring centered	(ms)	65	80	50	90	35	105					
	2-position valve	(ms)	100	130	75	100	60	115					
	3-position valve Solenoid operated - hydraulic centered	(ms)	a	b	a	b	a	b	a	b	a	b	
			55	35	100	105	40	45	85	95	35	40	
			85	95	35	40	85	95	35	40	85	95	
	Switching time for valve from operating position to static position												
	3-position valve	(ms)	60 to 75 for ~; 50 for =										
	2-position valve	(ms)	115...130	90	85...100	70	65...80	65					
3-position valve - hydraulic centered	(ms)	From-	a	b	a	b	a	b	a	b	a	b	
		30...65	30	40	60...90	30	40	105...155	50	50			

Characteristic curve

Model 4WEH10...(Measured at  $\nu_{oil}=41\text{mm}^2/\text{s}$  and  $t=50^\circ\text{C}$ )

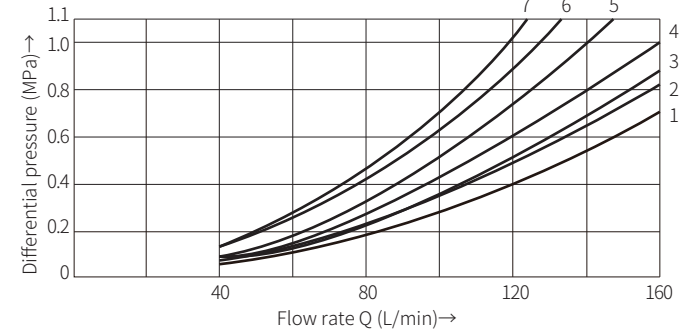

Spool	Working position				Spool	Working position		
	P-A	P-B	A-T	B-T		A-T	B-T	P-T
E, D, Y	2	2	4	5	F	3	-	6
F	1	4	1	4				
G, T	4	2	2	6	G,T	-	-	7
H, C	4	4	1	4				
J, K	1	2	1	3	H	1	3	5
L	2	3	1	4	L	3	-	-
M	4	4	3	4	P	-	7	5
Q, V, W, Z	2	2	3	5				
R	2	2	3	-	U	-	4	-
U	3	3	3	4				
P	4	1	3	4				

Characteristic limit

Model 4WEH10...(Measured at  $\nu_{oil}=41\text{mm}^2/\text{s}$  and  $t=50^\circ\text{C}$ )

Spool	Allowable flow of 2-position and 3-position valves (L/min)		
	Working pressure(MPa)		
	20	25	31.5
E, J, L, M, Q, R, U, V, W C, D, K, Z, Y	160		
H	160	150	120
G, T	160	160	140
F, P	160	140	120

Notice:

The given characteristic limits are suitable for the use of flow in both directions (e. g. from P to A and return from B to T at the same time).

Due to the power of the fluid in the valve, the characteristic limit allowed for only one flow direction might be significantly reduced (e.g. from P to A, while B is closed)!

The characteristic limits are measured when the solenoid is at the operating temperature, at 10% below the standard voltage and without tank preloading.

**Characteristic curve**

Model 4WEH16...(Measured at  $\vartheta_{oil}=41mm^2/s$  and  $t=50^\circ C$ )

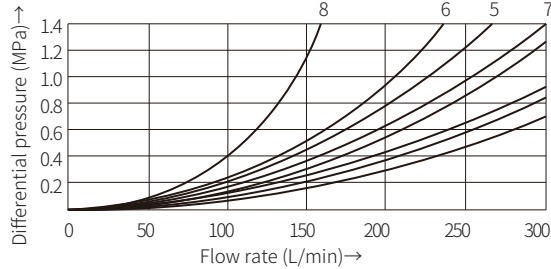

Spool	Working position				
	P-A	P-B	A-T	B-T	P-T
E, D, Y	1	1	1	3	-
F, P	2	2	3	3	-
G, T	5	1	3	7	6
H, C, Q, V, Z	2	2	3	3	-
J, K, L	1	1	3	3	-
M, W	2	2	4	3	-
R	2	2	4	-	-
U	1	1	4	7	-
S	4	4	4	-	8

**Characteristic limit**

Model 4WEH16...(Measured at  $\vartheta_{oil}=41mm^2/s$  and  $t=50^\circ C$ )

Allowable flow of 2-position valve (L/min)					
Spool	Working pressure(MPa)				
	7	14	21	28	35
Main valve spring return <sup>1)</sup>					
C, D, K, Z, Y	300	300	300	300	300
Main valve spring return <sup>2)</sup>					
C	300	300	300	300	300
D, Y	300	270	260	250	230
K	300	250	240	230	210
Z	300	260	190	180	160
Main valve hydraulic return					
HC, HD, HK	300	300	300	300	300
HZ, HY	300	300	300	300	300

- 1) The given flow value can be achieved when the minimum pilot pressure of 1.2MPa exists.
- 2) The given flow value is limiting the value at which the reset spring can return the valve when the pilot pressure decreases.

Allowable flow of 3-position valve (L/min)					
Spool	Working pressure(MPa)				
	7	14	21	28	35
Main valve spring return <sup>1)</sup>					
E, H, J, L, MQ, U, W, R	300	300	300	300	300
F, P	300	250	180	170	150
G, T	300	300	240	210	190
S	300	300	300	250	220
V	300	250	210	200	180
Pressure centered (minimum pilot pressure 1.6MPa)					
All spools	300	300	300	300	300

**Notice:**  
When using a 4/3-way valve with pressure centered in the main spool which exceeds the given performance limits, a higher pilot pressure is required. Therefore, if the pressure is 35MPa and the flow is 300L/min in the circuit, the pilot pressure of 1.6MPa is required.  
The maximum flow of the valve only depends on the acceptable pressure drop through the valve.

**Characteristic curve**

Model 4WEH22...(Measured at  $\vartheta_{oil}=41mm^2/s$  and  $t=50^\circ C$ )

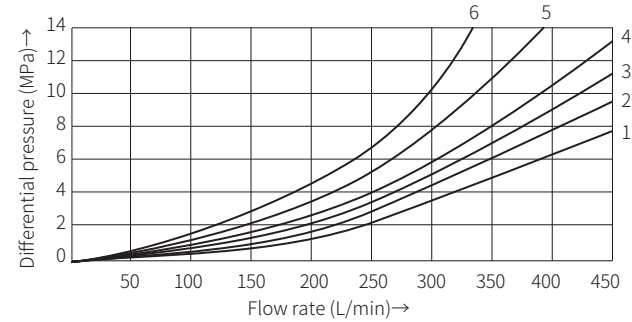

Spool	Switching position			
	P-A	P-B	A-T	B-T
E, M, P, Q, U, V	2	2	1	4
F	1	2	1	2
G, T	2	2	2	4
H, J, W	2	2	1	3
L	2	2	1	2
R	1	2	1	-

Spool	Neutral position		
	A-T	B-T	P-T
F	-	-	4
G, P	-	-	6
H	-	-	2
L	4	-	-
T	-	-	5
U	-	6	-

**Characteristic limit**

Model 4WEH22...(Measured at  $\vartheta_{oil}=41mm^2/s$  and  $t=50^\circ C$ )

Allowable flow of 2-position valve L/min					
Spool	working pressure(MPa)				
	7	14	21	28	35
X external supply main valve spring return (with $P_{pilot\ min}=11bar/14bar$ )					
C, D, K, Y, Z	450	450	450	450	450
X external supply main valve spring return <sup>1)</sup>					
C	450	450	320	250	200
D, Y	450	450	450	400	320
K	450	215	150	120	100
Z	350	300	290	260	160
X external supply hydraulic centered					
HC, HD, HK, HY, HZ	450	450	450	450	450
HC../O..	450	450	450	450	450
HD../O..	450	450	450	450	450
HK../O..	450	450	450	450	450
HZ../O..	450	450	450	450	450
HC../OF..	450	450	450	450	450
HD../OF..	450	450	450	450	450
HK../OF..	450	450	450	450	450
HZ../OF..	450	450	450	450	450

Allowable flow of 3-position valve L/min					
Spool	working pressure(MPa)				
	7	14	21	28	35
X external supply spring centered					
E, J, L, M, Q, U, W, R	450	450	450	450	450
H	450	450	300	260	230
G	400	350	250	200	180
F	450	270	175	130	110
V	450	300	240	220	160
T	400	300	240	200	160
P	450	270	180	170	110

When internal supply, a back pressure valve is required because of negative cover of spools Z, HZ, V and the flow less than 180L/min. It is also required due to negative cover of spools F, G, M, P and T.

- 1) The specified flow value is the limited value at which the reset spring can return the spool back to the end position when the pilot pressure disappears.

**Characteristic curve**

Model 4WEH25...(Measured at  $\dot{v}_{oil}=41\text{mm}^2/\text{s}$  and  $t=50^\circ\text{C}$ )

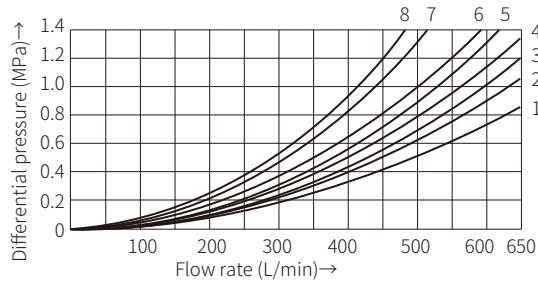

Spool	Working position				Spool	Working position			
	P-A	P-B	A-T	B-T		P-A	P-B	A-T	B-T
E	1	1	1	3	P	4	1	1	5
F	1	4	3	3	Q	2	2	3	5
G	3	1	2	4	Z	1	1	1	-
H	4	4	3	4	U	2	1	1	6
J	2	2	3	5	V	4	4	3	6
L	2	2	3	3	W	1	1	1	3
M	4	4	1	4	T	3	1	2	4

**Characteristic limit**

Model 4WEH25...(Measured at  $\dot{v}_{oil}=41\text{mm}^2/\text{s}$  and  $t=50^\circ\text{C}$ )

Allowable flow of 2-position valve (L/min)						with pre-load valve and X port internal supply
Spool	Working pressure(MPa)					
	7	14	21	28	35	
Main valve spring return <sup>1)</sup>						Spools C and Z approx. to 180 L/min
C, D, K, Z, Y	700	700	700	700	700	
Main valve spring return <sup>2)</sup>						
C	700	700	700	700	700	
D, Y	700	650	400	350	300	
K	700	650	420	370	320	
Z	700	700	650	480	400	
Main valve hydraulic return						Spools HC and HZ approximately to 180L/min
HC, HD, HK	700	700	700	700	700	
HZ, HY	700	700	700	700	700	
HC.../O	700	700	700	700	700	
HD.../O	700	700	700	700	700	
HK.../O	700	700	700	700	700	
HZ.../O	700	700	700	700	700	
HC.../OF	700	700	700	700	700	
HD.../OF	700	700	700	700	700	
HK.../OF	700	700	700	700	700	
HZ.../OF	700	700	700	700	700	

  

Allowable flow of 3-position valve (L/min)						with pre-load valve and X port internal supply
Spool	Working pressure(MPa)					
	7	14	21	28	35	
spring centered						Spools F, G, HP and T approximately to 180L/min
E, L, M	700	700	700	700	650	
Q, U, W	700	700	700	700	400	
G/T	400	400	400	400	400	
F	650	550	430	330	300	
H	700	650	550	400	360	
J	700	700	650	600	520	
P	650	550	430	330	300	
V	650	550	400	350	310	
R	700	700	700	650	680	
Pressure centered (minimum pilot pressure 1.8MPa)						
E/F/H/J	700	700	700	700	650	
L/M/P/Q	700	700	700	700	650	
R/U/V/W	700	700	700	700	650	
G/T	400	400	400	400	400	
When the pilot pressure higher than 3MPa						
G/T	700	700	700	700	700	

- 1) The given flow value can be achieved when the minimum pilot pressure of 1.3MPa exists.
- 2) The given flow value is limiting the value at which the reset spring can return the valve when the pilot pressure decreases.

**Characteristic curve**

Model 4WEH32...(Measured at  $\dot{v}_{oil}=41\text{mm}^2/\text{s}$  and  $t=50^\circ\text{C}$ )

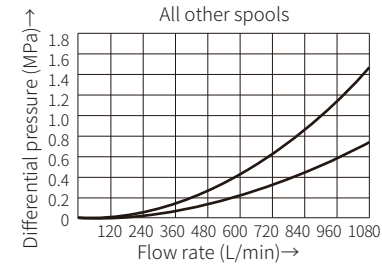
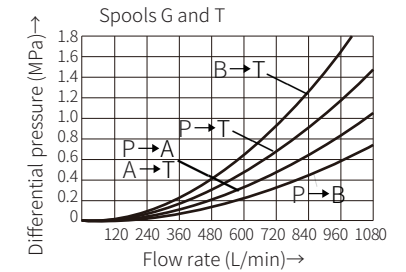
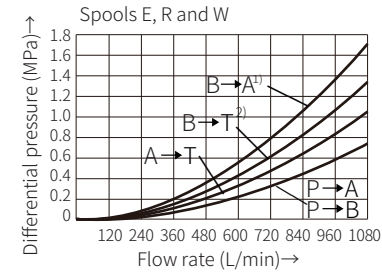

- 1) Only for spool R
- 2) Not for spool R

**Characteristic limit**

Model 4WEH32...(Measured at  $\dot{v}_{oil}=41\text{mm}^2/\text{s}$  and  $t=50^\circ\text{C}$ )

Allowable flow of 2-position valve (L/min)						with pre-load valve and X port internal supply
Spool	Working pressure(MPa)					
	7	14	21	28	25	
Main valve spring return <sup>1)</sup>						Spool Z approx to 180L/min
C, D, K, Z, Y	1100	1040	860	750	680	
Main valve spring return <sup>2)</sup>						
C	1100	1040	860	800	700	
D, Y	1100	1040	540	480	420	
K	1100	1040	860	500	450	
Z	1100	1040	860	750	650	
Main valve hydraulic return						
HC, HD, HK	1100	1040	860	750	680	
HZ, HY	1100	1040	860	750	680	

Allowable flow of 3-position valve (L/min)						with pre-load valve and X port internal supply
Spool	Working pressure(MPa)					
	7	14	21	28	25	
Main valve spring return <sup>1)</sup>						Spools F, G, H, P and T approximately to 180L/min
E, H, J, L, M	1100	1040	860	750	680	
Q, U, W, R	1100	1040	860	750	680	
G, T, H, F, P	900	900	800	650	450	
V	1100	1000	680	500	450	
Pressure centered (minimum pilot pressure 0.85MPa)						
All spools	1100	1040	860	750	680	

**Notice:**

When using a 4/3-way valve with pressure centered in the main spool which exceeds the given performance limits, a higher pilot pressure is required. Therefore, if the pressure is 35MPa and the flow is 300L/min in the circuit, the pilot pressure of 1.5MPa is required. The maximum flow of the valve only depends on the acceptable pressure drop through the valve.

- 1) The given flow value can be achieved when the minimum pilot pressure of 1.0MPa exists.
- 2) The given flow value is limiting the value at which the reset spring can return the valve when the pilot pressure decreases.

Switching time adjustment, pressure reducing valve and pre-load valve

Switching time adjustment

To control the switching time of the main valve (1), a double throttle check valve (12) is installed between the pilot valve and the main valve. Conversion from meter-in control (13) to meter-out control (14): Remove the pilot valve (4) but retain the O-ring support plate (15), turn the throttle check valve around its longitudinal axis and reassemble it on the mounting surface, install the pilot valve (4). Tightening torque  $M_A=9Nm$  for fixing screw (16).

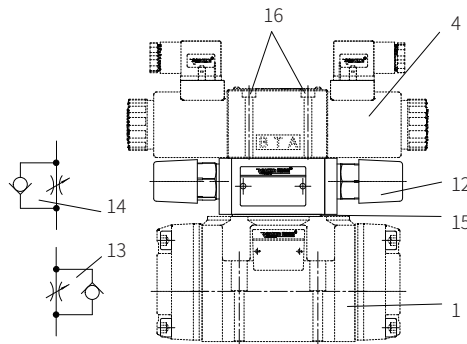

Model 4WEH.../S or S2

Pressure reducing valve "D3"

The pressure reducing valve (17) must be used if the pilot pressure exceeds 25MPa. The secondary pressure should be maintained at 4.5MPa. When using the pressure reducing valve D3, it must install a plug-in throttle B10 in port P of the pilot valve. Tightening torque  $M_A=9Nm$  for fixing screw (16).

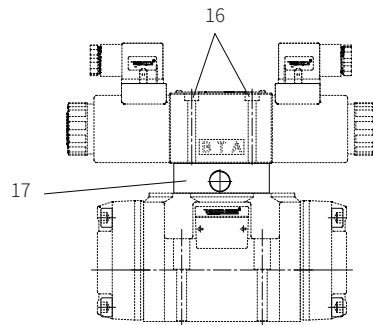

Model 4WEH.../.../D3

Pre-load valve (not for size 10)

In the valve with pressureless bypass and internal pilot oil supply, a pre-load valve (18) is installed in port P of the main valve to built up the minimum pilot pressure.

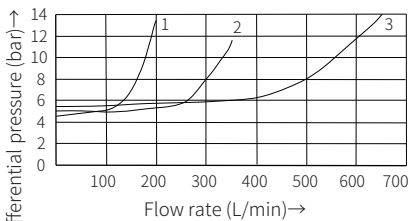

- 1 Size 16
- 2 Size 25
- 3 Size 32

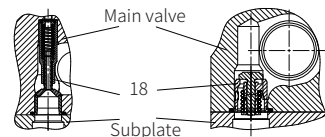

Model 4WEH16...-7X/.../P4.5      Model 4WEH25.../.../P4.5  
Model 4WEH32.../.../P4.5

Component size

Size unit: mm

WEH10...4XJ/...

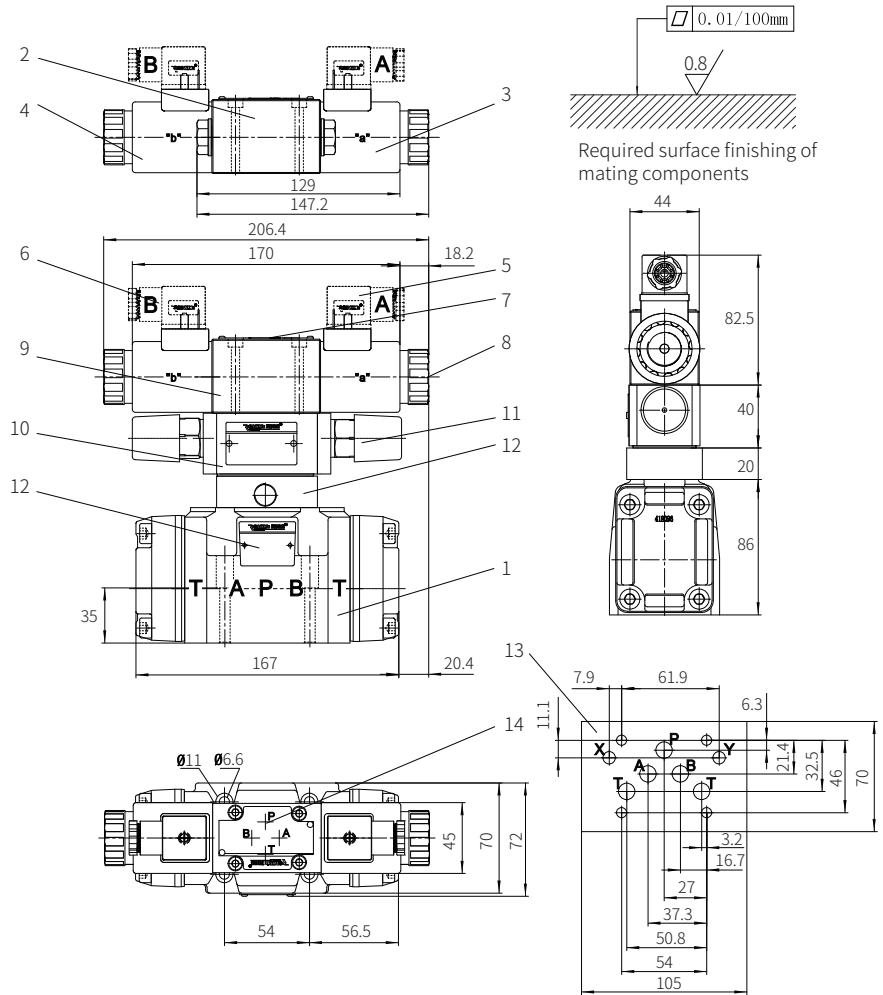

- 1 Main valve
- 2 2-position valve with one solenoid and plug Z4
- 3 Solenoid a
- 4 Solenoid b
- 5 Gray plug (or transparent plug)
- 6 Black plug (or transparent plug)
- 7 Name plate of pilot valve
- 8 Manual emergency operation
- 9 2-position or 3-position valve with two solenoids and plug Z4
- 10 Switching time adjustment
- 11 Adjustment bolt
- 12 Pressure reducing valve
- 13 Port layout of main valve (valve mounting surface)
- 14 Port position of pilot oil
- 15 Name plate of complete valve
- Valve fixing screw  
M6x45-10.9 grade GB/T70.1-2000
- Tightening torque  $M_A=13.7Nm$

**Component size**

Size unit: mm

**Dimension of additional devices for model WEH10**

The installation range of the stroke adjustment is 6.5mm. The stroke limiter is used to adjust the stroke of the main spool. Loosen the lock nut and rotate the adjusting rod clockwise, the stroke of the main spool will be shortened (the adjustment must be carried out without pressure in the control chamber)

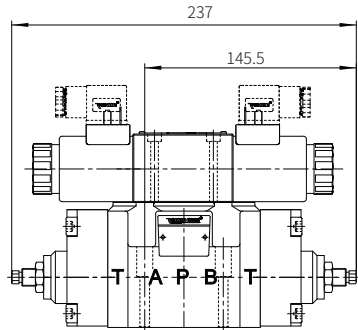
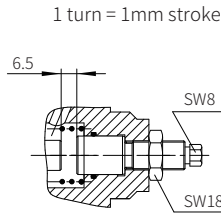

- Stroke adjustment installed on the ends A and B of the main valve.../10
- Stroke adjustment installed on the end A of the main valve.../11
- Stroke adjustment installed on the end B of the main valve.../12

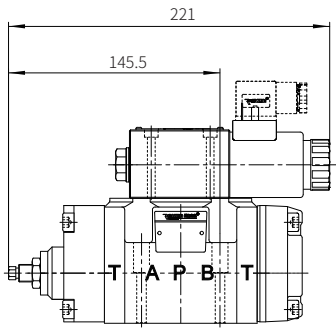

- Stroke adjustment installed on the end A of the main valve.../11
- (2-position valve, symbols C, D, K, Z)

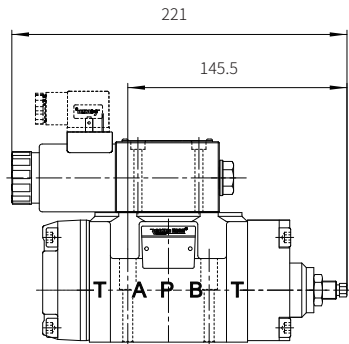

- Stroke adjustment installed on the end B of the main valve.../12
- (2-position valve, symbol Y)

**Component size**

Size unit: mm

WEH16...7XJ/...

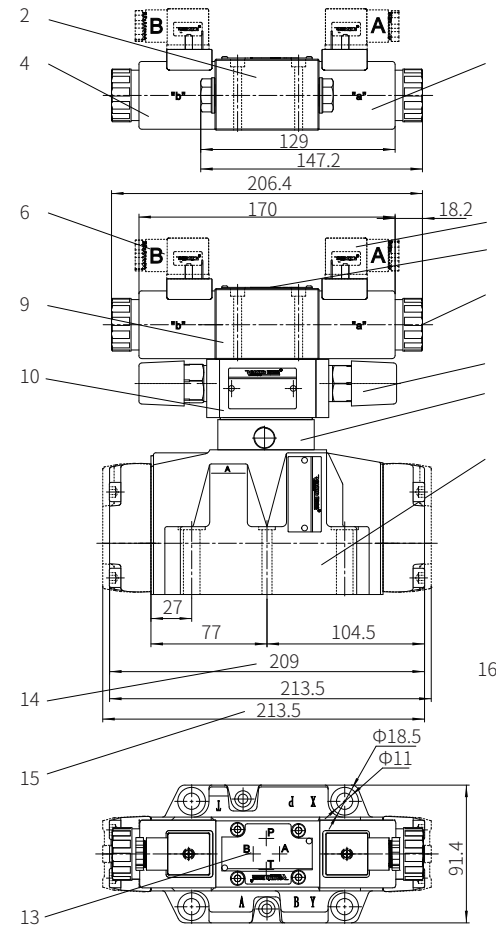

- 1 Main valve
- 2 2-position valve with one solenoid and plug Z4
- 3 Solenoid a
- 4 Solenoid b
- 5 Gray plug (or transparent plug)
- 6 Black plug (or transparent plug)
- 7 Name plate of pilot valve
- 8 Manual emergency operation
- 9 2-position or 3-position valve with two solenoids and plug Z4
- 10 Switching time adjustment
- 11 Adjustment bolt
- 12 Pressure reducing valve
- Valve fixing screw
- 2-M6x55-10.9 grade GB/T70.1-2000
- Tightening torque  $M_A=13.7Nm$

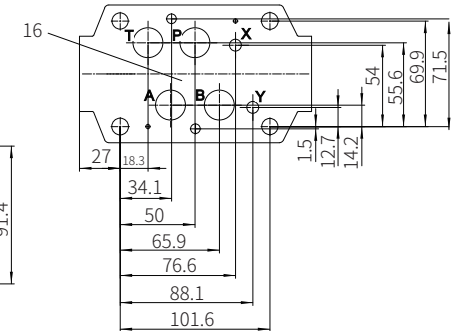
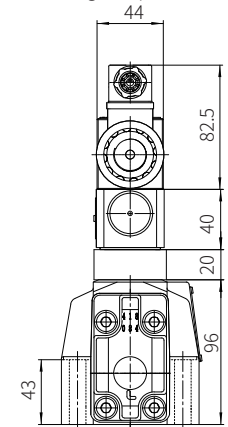
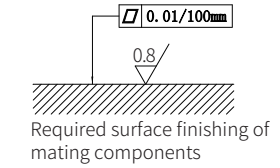

- 13 Port layout of main valve (valve mounting surface)
- 14 Size of 3-position valve with spring centered
- 15 Size of 2-position valve with spring centered
- 16 Main valve connection diagram

- 4-M10x60-10.9 grade GB/T70.1-2000
- Tightening torque  $M_A=60Nm$

## Component size

Size unit: mm

## Dimension of additional devices for model WEH16

The installation range of the stroke adjustment is 10mm. The stroke limiter is used to adjust the stroke of the main spool. Loosen the lock nut and rotate the adjusting rod clockwise, the stroke of the main spool will be shortened (the adjustment must be carried out without pressure in the control chamber)

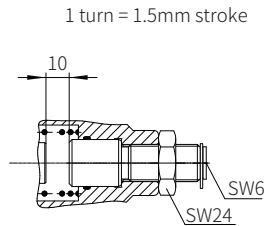

Stroke adjustment installed on the ends A and B of the main valve.../10  
 Stroke adjustment installed on the end A of the main valve.../11  
 Stroke adjustment installed on the end B of the main valve.../12

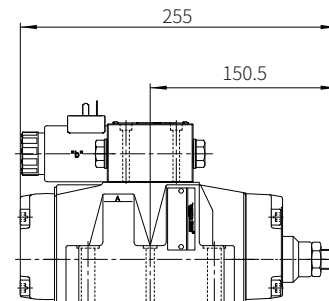
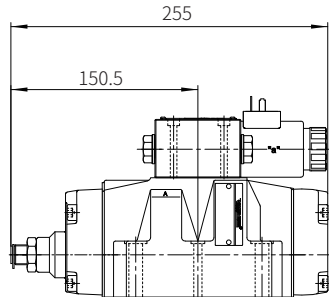
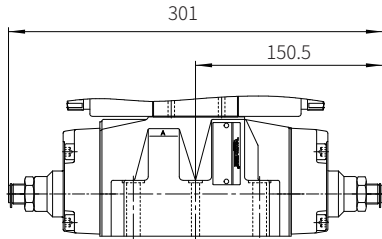

Stroke adjustment installed on the end A of the main valve.../11  
 (2-position valve, symbols C, D, K, Z)

Stroke adjustment installed on the end B of the main valve.../12  
 (2-position valve, symbol Y)

## Component size

Size unit: mm

## WEH22...7XJ/...

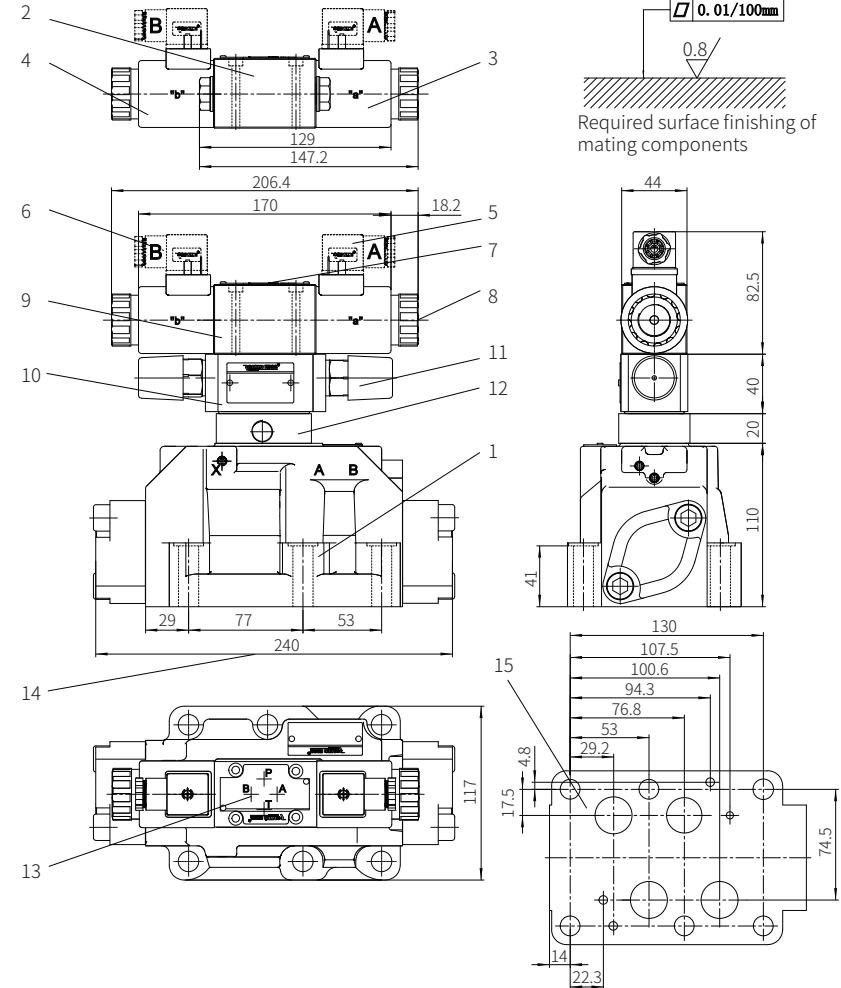

- |  |   |
|--|---|
| 1 Main valve                                     | 7 Name plate of pilot valve                                     |
| 2 2-position valve with one solenoid and plug Z4 | 8 Manual emergency operation                                    |
| 3 Solenoid a                                     | 9 2-position or 3-position valve with two solenoids and plug Z4 |
| 4 Solenoid b                                     | 10 Switching time adjustment                                    |
| 5 Gray plug (or transparent plug)                | 11 Adjustment bolt  |
| 6 Black plug (or transparent plug)               | 12 Pressure reducing valve                                      |

- 13 Port layout of main valve (valve mounting surface)  
 14 Size of 3-position valve with spring centered  
 15 Main valve connection diagram

Valve fixing screw  
 6-M12x60-10.9 grade GB/T70.1-2000  
 Tightening torque  $M_A=95Nm$

## Component size

Size unit: mm

WEH25...6XJ/...

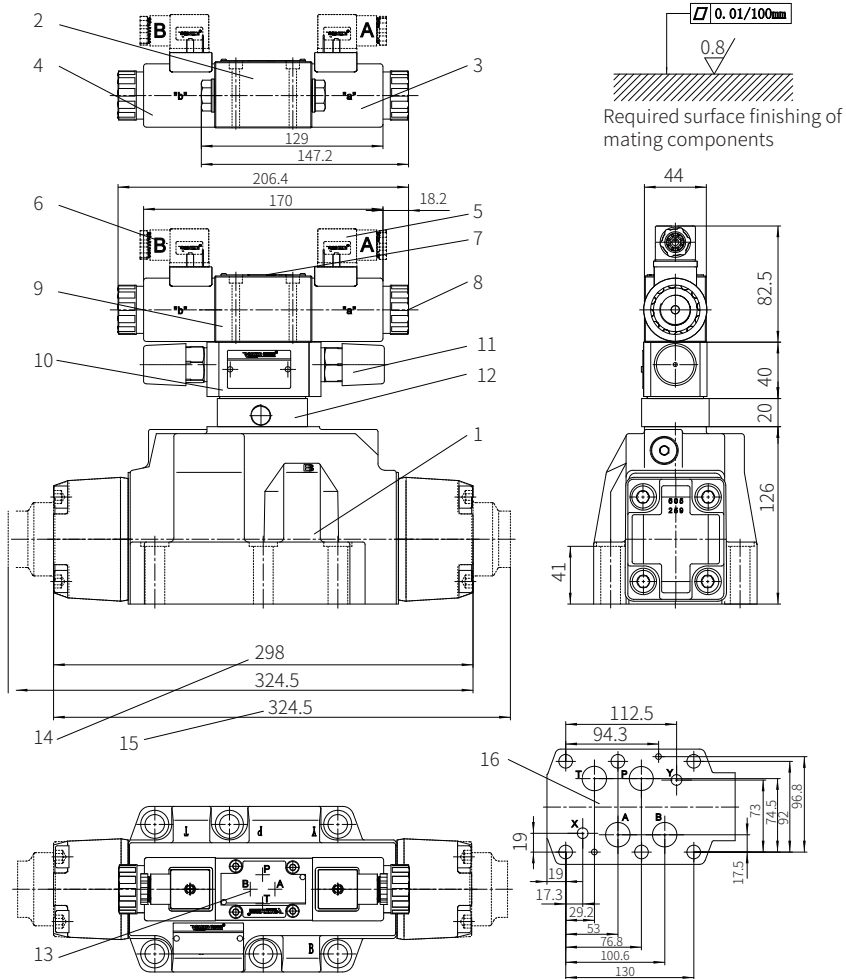

- |  |   |
|--|---|
| 1 Main valve                                     | 7 Name plate of pilot valve                                     |
| 2 2-position valve with one solenoid and plug Z4 | 8 Manual emergency operation                                    |
| 3 Solenoid a                                     | 9 2-position or 3-position valve with two solenoids and plug Z4 |
| 4 Solenoid b                                     | 10 Switching time adjustment                                    |
| 5 Gray plug (or transparent plug)                | 11 Adjustment bolt  |
| 6 Black plug (or transparent plug)               | 12 Pressure reducing valve                                      |

- 13 Port layout of main valve (valve mounting surface)  
14 Size of 3-position valve with spring centered  
15 Size of 2-position valve with spring centered  
16 Main valve connection diagram

Valve fixing screw  
6-M12x60-10.9 grade GB/T70.1-2000  
Tightening torque  $M_A = 95\text{Nm}$

## Component size

Size unit: mm

## Dimension of additional devices for model WEH25

The installation range of the stroke adjustment is 12.5mm. The stroke limiter is used to adjust the stroke of the main spool. Loosen the lock nut and rotate the adjusting rod clockwise, the stroke of the main spool will be shortened (the adjustment must be carried out without pressure in the control chamber)

1 turn = 1.5mm stroke

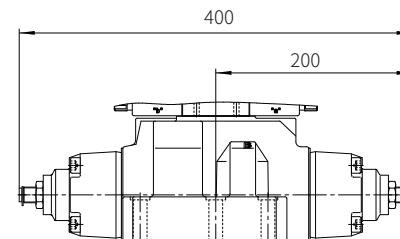
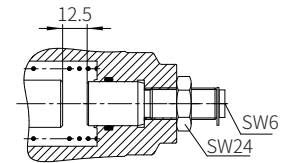

- Stroke adjustment installed on the ends A and B of the main valve.../10  
Stroke adjustment installed on the end A of the main valve.../11  
Stroke adjustment installed on the end B of the main valve.../12

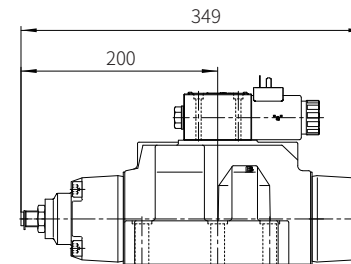

- Stroke adjustment installed on the end A of the main valve.../11  
(2-position valve, symbols C, D, K, Z)

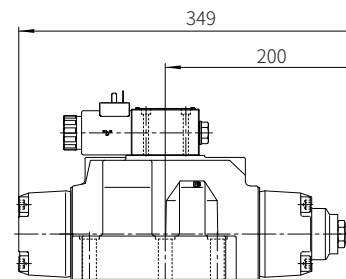

- Stroke adjustment installed on the end B of the main valve.../12  
(2-position valve, symbol Y)

## Component size

Size unit: mm

WEH32...6XJ/...

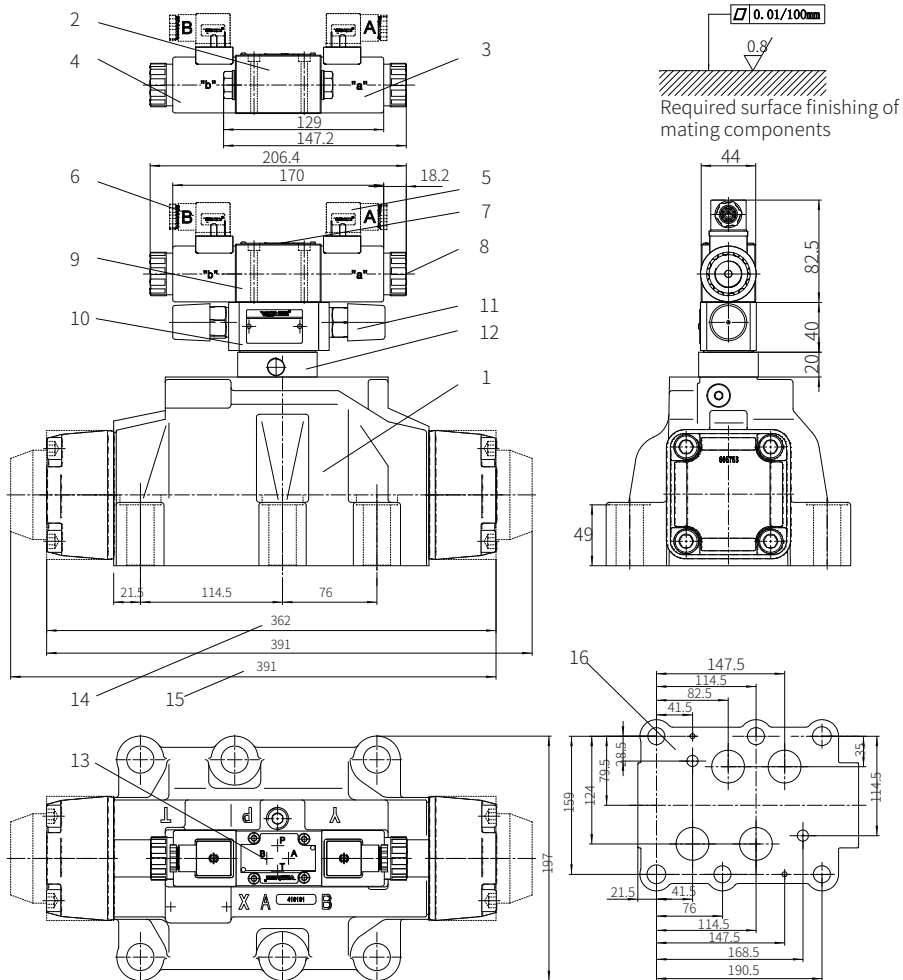

- |  |   |
|--|---|
| 1 Main valve                                     | 7 Name plate of pilot valve                                     |
| 2 2-position valve with one solenoid and plug Z4 | 8 Manual emergency operation                                    |
| 3 Solenoid a                                     | 9 2-position or 3-position valve with two solenoids and plug Z4 |
| 4 Solenoid b                                     | 10 Switching time adjustment                                    |
| 5 Gray plug (or transparent plug)                | 11 Adjustment bolt  |
| 6 Black plug (or transparent plug)               | 12 Pressure reducing valve                                      |

- 13 Port layout of main valve (valve mounting surface)  
 14 Size of 3-position valve with spring centered  
 15 Size of 2-position valve with spring centered  
 16 Main valve connection diagram

Valve fixing screw  
 6-M20x80-10.9 grade GB/T70.1-2000  
 Tightening torque  $M_A=373\text{Nm}$

## Component size

Size unit: mm

## Dimension of additional devices for model WEH32

The installation range of the stroke adjustment is 15mm. The stroke limiter is used to adjust the stroke of the main spool. Loosen the lock nut and rotate the adjusting rod clockwise, the stroke of the main spool will be shortened (the adjustment must be carried out without pressure in the control chamber)

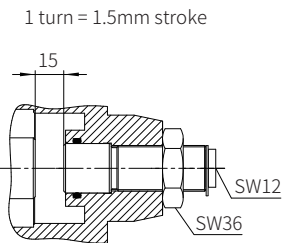

1 turn = 1.5mm stroke  
 Stroke adjustment installed on the ends A and B of the main valve.../10  
 Stroke adjustment installed on the end A of the main valve.../11  
 Stroke adjustment installed on the end B of the main valve.../12

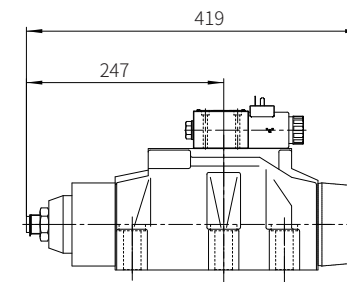
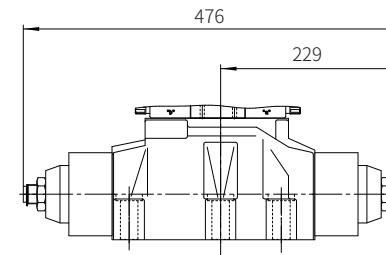

Stroke adjustment installed on the end A of the main valve.../11  
 (2-position valve, symbols C, D, K, Z)

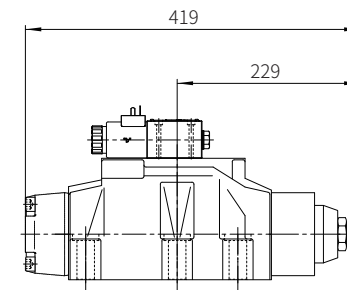

Stroke adjustment installed on the end B of the main valve.../12  
 (2-position valve, symbol Y)