

Modular Pressure Relief Valve

Model: ZDB/Z2DB10...4XJ



- ◆ Size 10
- ◆ Maximum working pressure 315 bar
- ◆ Maximum working flow 100 L/min

Contents

Function description, sectional drawing	02
Models and specifications	02
Functional symbols	03
Technical parameters	03
Characteristic curve	04
Component size	05-07

Features

- Cartridge valve
- 4 pressure ranges
- 6 circuit options
- With one or two cartridge relief valves
- 4 adjustment elements
 - Rotary knob
 - Hexagon screw with sleeve and protective cap
 - Lockable rotary knob with scale
 - Rotary knob with scale

Any part of this brochure can not be reproduced, edited, copied and disseminated electronically in any way without authorization of Jiayite Hydraulics company. As the product is in constant development and innovation, the information in this brochure is not specific to the special conditions or applicability of a specific industry, thus Jiayite Hydraulics company is not responsible for any incomplete or inaccurate description generated.



Function description, sectional drawing

The ZDB and Z2DB type relief valve is pilot operated relief valve with sandwich plate design. It's used to limit the pressure within hydraulic system.

The valve is mainly composed of valve body (7), and together with one or two cartridge relief valves. The system pressure is set by adjustment element (4).

At rest, the valve is closed. Pressure in port A acts on valve spool (1), at the same time pressure passes through orifice (2) to act on the spring loaded side of spool (1), and through orifice (3) to act on pilot valve spool (6). If pressure of port A rises above the value set on spring (5), then the pilot valve spool (6) opens.

Hydraulic oil flow from the spring loaded side of the spool (1), orifice (3) and channel (8) into port T. The resulting pressure drop moves the spool (1) thereby opening the connection A to T, while maintaining the pressure set at spring (5). Pilot oil return from two spring chambers via port T externally.

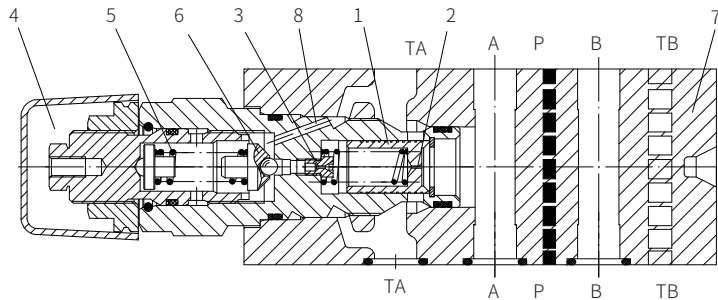

Model ZDB10VA2-...4XJ/

Models and specifications

Z	DB	10			4X	J		*
sandwich plate =Z								more information in text
2 cartridge relief valve =2 only for "VC" and "VD"								sealing material
pressure relief valve =DB								No code = NBR seals
size 10 =10								V= FKM seals (consult for other seals)
relief function from - to								50= pressure adjustable up to 50bar
A→TA =VA								100= pressure adjustable up to 100bar
P→TA =VP								200= pressure adjustable up to 200bar
TB1→TA2 =VT								315= pressure adjustable up to 315bar
B→TB =VB								
A→TA and B→TB =VC								
A→B and B→A =VD								
adjustment element								J= Rekith
rotary knob =1								4X= 40 to 49 series
hexagon screw with sleeve and protective cap =2								(40 to 49 series: installation and connection size unchanged)
lockable rotary knob with scale =3								
rotary knob with scale =7								

Functional symbols

(① = Valve side ② = Subplate side)

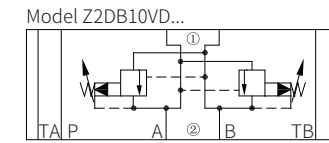
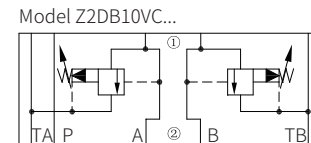
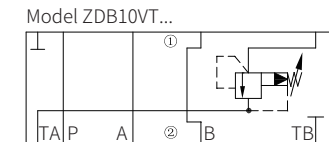
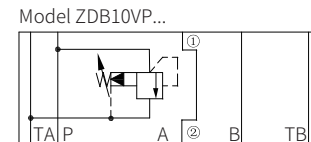
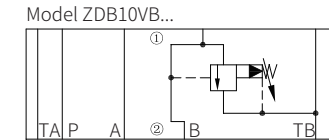
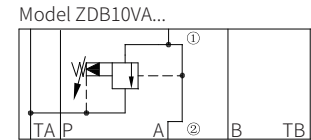

Technical parameters

Overview	
Installation position	optional
Working medium temperature range °C	-30 to +80 (NBR seals) -20 to +80 (FKM seals)
Weight	Model ZDB10 2.4KG Model Z2DB10 2.6KG
Hydraulic	
Maximum working pressure bar	to 315
Maximum adjustable pressure bar	50; 100; 200; 315
Maximum flow L/min	100
Oil fluid	Mineral oil (HL, HLP) ¹⁾ in accordance with DIN 51524; Fast living organisms degraded oil according to VDMA 24568; HETG (Rapeseed oil) ³⁾ HEPG (Polyethylene glycol) ²⁾ HEES (synthetic ester) ²⁾
Viscosity range mm ² /s	10 to 800
Cleanliness of oil ³⁾	The maximum allowable pollution level of oil is ISO4406 Class 20/18/15

1) For NBR seal and FKM seal.

2) Only for FKM seal.

3) The oil must meet the cleanliness degree requested by the components in the hydraulic system.

Effective oil filtration can prevent failure and increase the service life of the components.

Characteristic curve

(Measured when using HLP 46, $t_{oil} = 40^\circ\text{C} \pm 5^\circ\text{C}$)

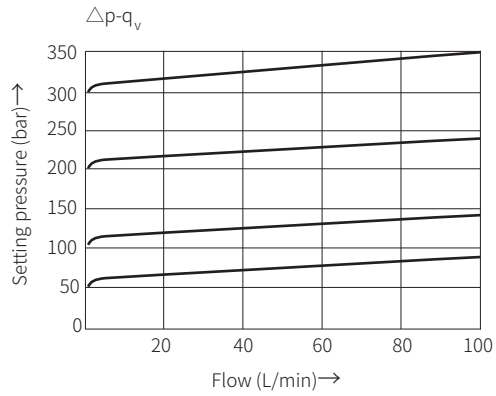

The characteristic curves are valid for an outlet pressure = zero over the entire flow range!

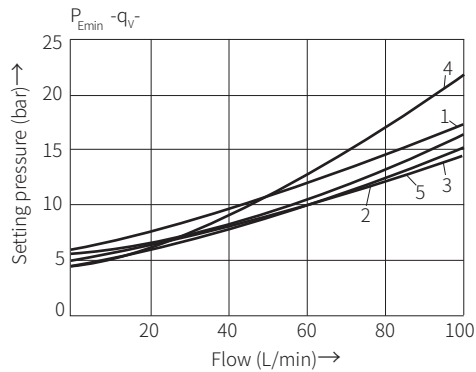

- 1.VD(A-B) 2.VA
- 3.VB/VC 4.VP/VD(B-A)

02

Component size

Size unit: mm

Model ZDB10VA...-4XJ/...and ZDB10VP...-4XJ/...

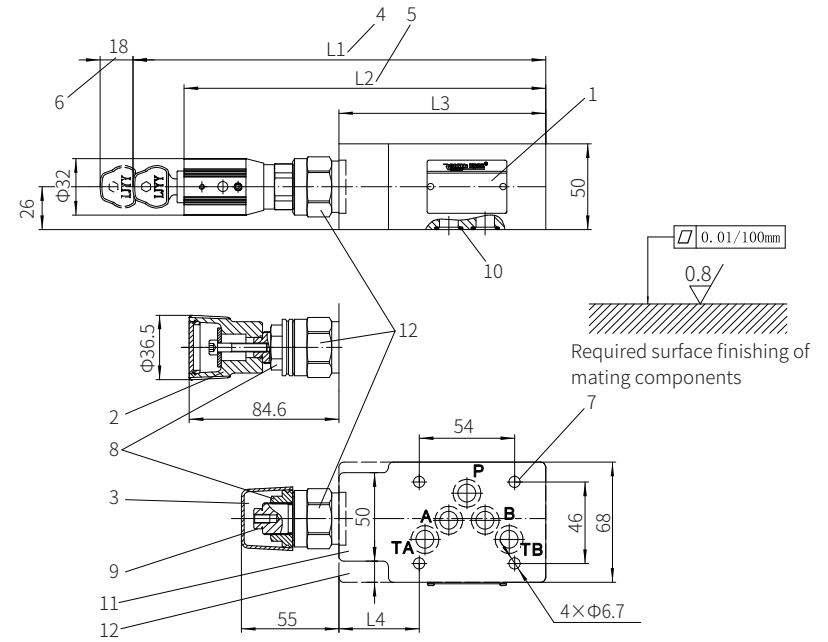

- 1 Name plate
- 2 Adjustment form "1"
- 3 Adjustment form "2"
- 4 Adjustment form "3"
- 5 Adjustment form "7"
- 6 Space required to remove the key
- 7 Valve fixing screw holes
- 8 Locknut S=24
- 9 External hexagon adjustment screw S=10
- 10 O ring 12x2 (for all ports)
- 11 Model ZDB10VA and ZDB10VP version
- 12 External hexagon S=30

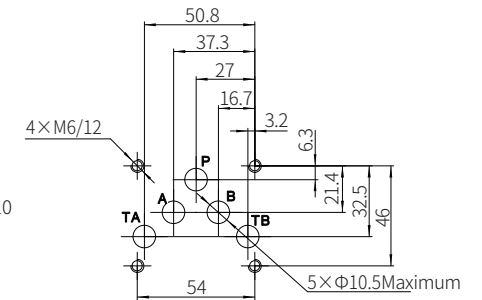

Valve fixing screw
M6-10.9 grade GB/T70.1-2000
Tightening torque $M_A = 13.7\text{Nm}$

Model	L1	L2	L3	L4
VA and VP	224.2	204.5	117	45.5

02

Component size

Size unit: mm

Model ZDB10VB...-4XJ/...

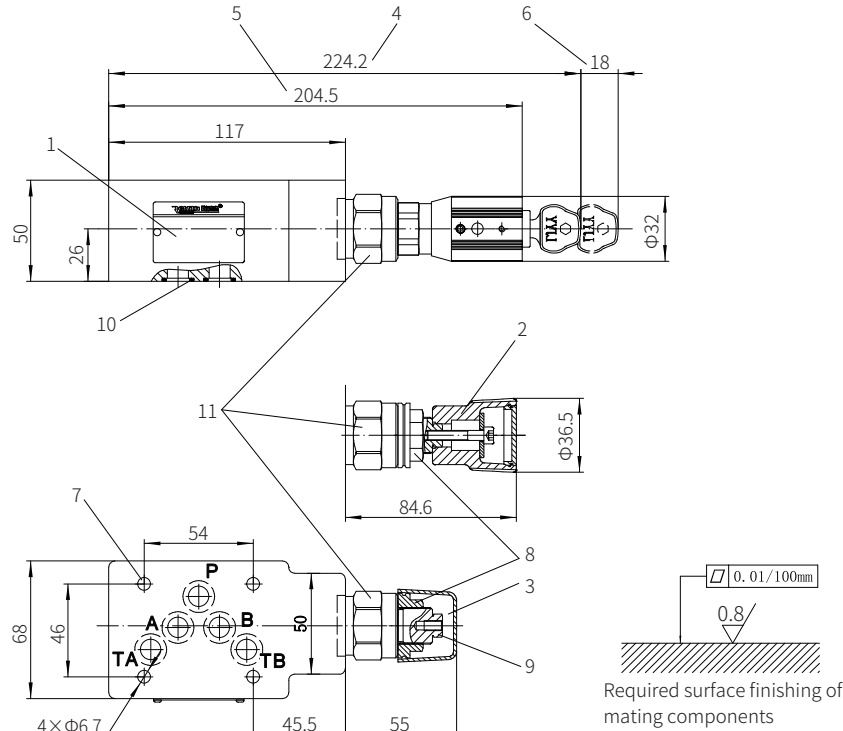

- 1 Name plate
- 2 Adjustment form "1"
- 3 Adjustment form "2"
- 4 Adjustment form "3"
- 5 Adjustment form "7"
- 6 Space required to remove the key
- 7 Valve fixing screw holes
- 8 Locknut S=24
- 9 External hexagon adjustment screw S=10
- 10 O ring 12x2 (for all ports)
- 11 External hexagon S=30

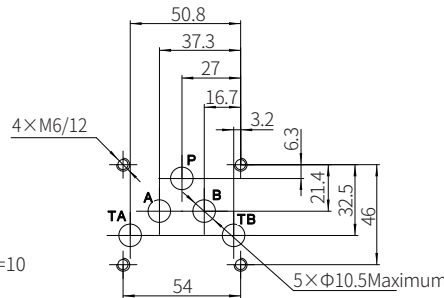

Valve fixing screw
M6-10.9 grade GB/T70.1-2000
Tightening torque $M_A=13.7\text{Nm}$

Component size

Size unit: mm

Model Z2DB10VC...-4XJ/...and Z2DB10VD...-4XJ/...

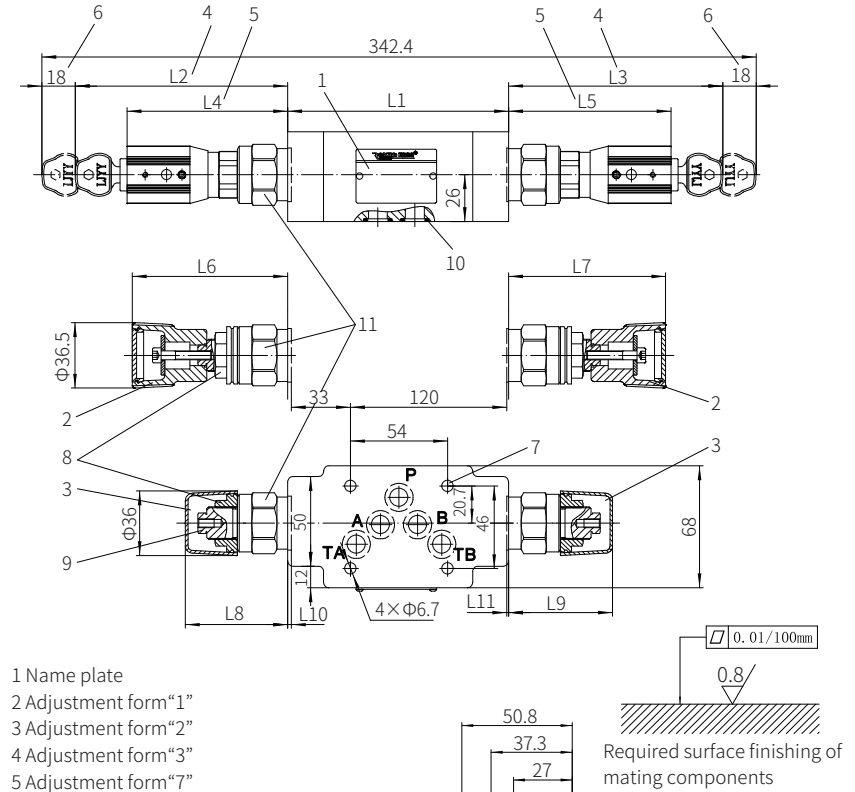

- 1 Name plate
 - 2 Adjustment form "1"
 - 3 Adjustment form "2"
 - 4 Adjustment form "3"
 - 5 Adjustment form "7"
 - 6 Space required to remove the key
 - 7 Valve fixing screw holes
 - 8 Locknut S=24
 - 9 External hexagon adjustment screw S=10
 - 10 O ring 12x2 (for all ports)
 - 11 External hexagon S=30
- Valve fixing screw
M6-10.9 grade GB/T70.1-2000
Tightening torque $M_A=13.7\text{Nm}$

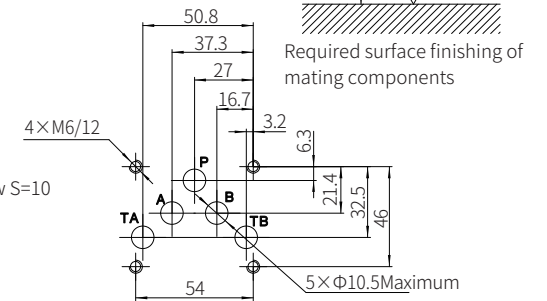

Model	L1	L2	L3	L4	L5	L6	L7	L8	L9	L10	L11
VC	123	109.2	110.2	89.5	90.5	86.5	87.5	57	58	2	1
VD	132	105.2	105.2	85.5	85.5	82.5	82.5	53	53	6	6