

## Modular Restrictive Check Valve

Model: Z2FS10...3XJ



- ◆ Size 10
- ◆ Maximum working pressure 315 bar
- ◆ Maximum working flow 160 L/min

### Contents

Function description, sectional drawing	02
Models and specifications	02
Functional symbols	03
Technical parameters	03
Characteristic curve	04
Component size	05

### Features

- Modular type valve
- 3 types of adjustment elements
  - Adjusting screw with inner hexagonal locknut and protective cap
  - Lockable knob with scale
  - Rotary knob with scale
- Used to limit the main flow or control flow of two working oil ports
- Used for meter-in or meter-out control

Any part of this brochure can not be reproduced, edited, copied and disseminated electronically in any way without authorization of Jiayite Hydraulics company. As the product is in constant development and innovation, the information in this brochure is not specific to the special conditions or applicability of a specific industry, thus Jiayite Hydraulics company is not responsible for any incomplete or inaccurate description generated.



## Function description, sectional drawing

The Z2FS10 type valve is a double throttle check valve with a stacked design.

This valve is used to limit the main flow or control flow of one or two working oil ports. Two symmetrically arranged throttle check valves limit the flow in one direction (by adjusting the throttle valve core) and allow free flow in the opposite direction.

For meter-in control the oil fluid flows from port A1 to A2 through the throttle port (1) which is made of the valve body (2) and throttle spool (3.1). The throttle spool (3.1) can be axially adjusted via the adjusting screw (4) to adjust throttle port (1). At the same time, the oil at port A1 flows through the oil hole to the spool (6) and results a pressure which force the throttle spool (3.1) in the throttle position together with the spring force.

The oil flowing back from the working oil port B2 opens the throttle spool (3.2) against the force of spring (7) to make the valve to act as a check valve and allow free-flow. According to the installation position of the valve, the throttling effect can be meter-in or meter-out control.

Main flow limit

To change velocity of the actuator (main flow control), the double throttle/check valve is installed between the directional control valve and the subplate.

Control flow limit

In the pilot operated directional control valves, the double throttle/check valve is installed between the pilot valve and the main valve to control damping adjustment (control flow limit).

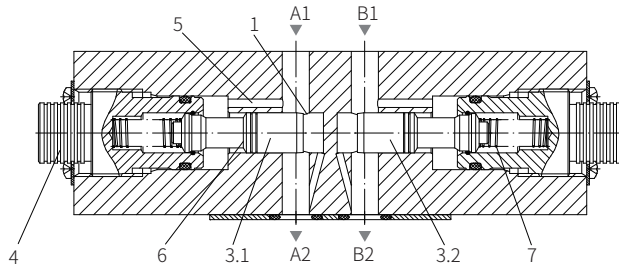

Model Z2FS10-5-3XJ/(meter-in control)

## Models and specifications

modular restrictive check Valve	Z2FS	10	-3X	J	*	more information in text
size 10	=Z2FS	=10				sealing material
throttle check valve, oil port A and B	=-					No code= NBR seals
throttle check valve, oil port A	=A					V= FKM seals
throttle check valve, oil port B	=B					(consult for other seals)
adjusting elements						S= meter-in control on side A (...A.-3X/S)
lockable knob with scale	=3					meter-in control on side B (...B.-3X/S)
Adjusting screw with inner hexagonal locknut and protective cap	=5					S2= meter-out control on side A (...A.-3X/S2)
Rotary knob with scale	=7					meter-out control on side B (...B.-3X/S2)
30 to 39 series		=3X				J= Rekith
(30 to 39 series installation and connection size unchanged)						

## Functional symbols

(①=Valve side ②=Subplate side)

Model Z2FS10-...-3XJ/...(meter-in control)

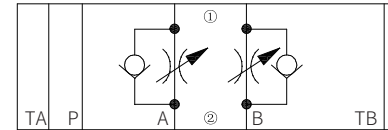

Model Z2FS10-...-3XJ/...(meter-out control)

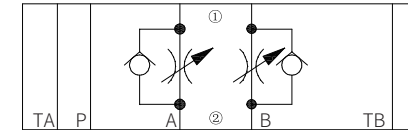

Model Z2FS10A-...-3XJ/...(meter-in control)

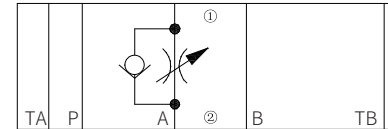

Model Z2FS10A-...-3XJ/...(meter-out control)

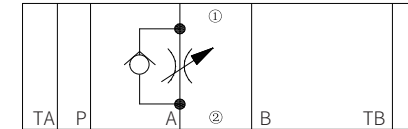

Model Z2FS10B-...-3XJ/...(meter-in control)

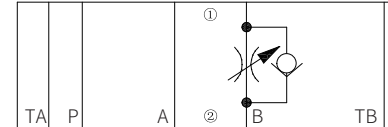

Model Z2FS10B-...-3XJ/...(meter-out control)

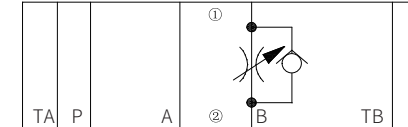

## Technical parameters

Overview		Optional
Installation position		
Environment temperature range	°C	-30 to +50 (NBR seal) -20 to +50 (FKM seal)
Weight	kg	about 3.1
Hydraulic		
Maximum working pressure	bar	to 315
Maximum flow	L/min	160
Oil fluid		Mineral oil (HL, HLP) <sup>1)</sup> in accordance with DIN 51524; Fast living organisms degraded oil according to VDMA 24568; HETG (Rapeseed oil) <sup>1)</sup> ; HEPG (Polyethyleneglycol) <sup>2)</sup> ; HEES (Synthetic Fats) <sup>2)</sup>
Pressure medium temperature range	°C	-20 to +80
Viscosity range	mm <sup>2</sup> /s	10 to 800
Cleanliness of oil <sup>3)</sup>		The maximum allowable pollution level of oil is ISO4406 class 20 / 18 / 15

1) For NBR seal and FKM seal.

2) Only for FKM seal.

3) The oil must meet the cleanliness degree requested by the components in the hydraulic system.

Effective oil filtration can prevent failure and increase the service life of the components.

Characteristic curve

(Measured when using HLP 46,  $t_{oil} = 40^{\circ}\text{C} \pm 5^{\circ}\text{C}$ )

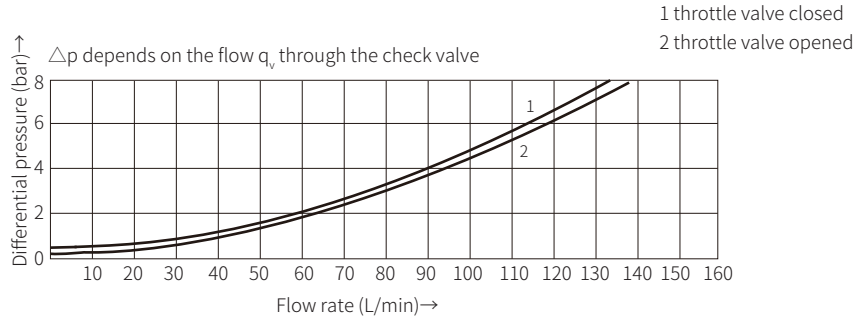

The pressure drop  $\Delta p$  depends on the flow  $q_v$  at a constant throttle setting

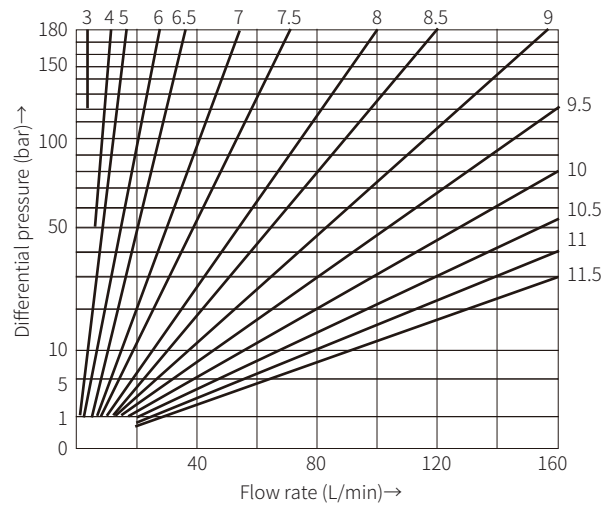

Component size

Size unit: mm

Model Z2FS10A-7-3XJ/...

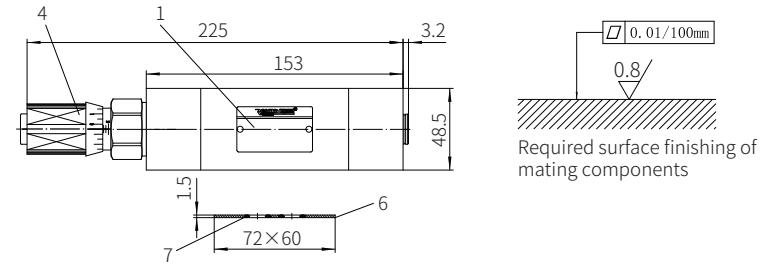

Model Z2FS10B-5-3XJ/...

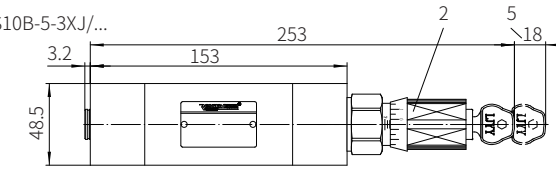

Valve fixing screw  
M6-10.9 grade GB/T70.1-2000  
Tightening torque  $M_A = 13.7\text{Nm}$   
It must be ordered separately

Model Z2FS10-3-3XJ/...

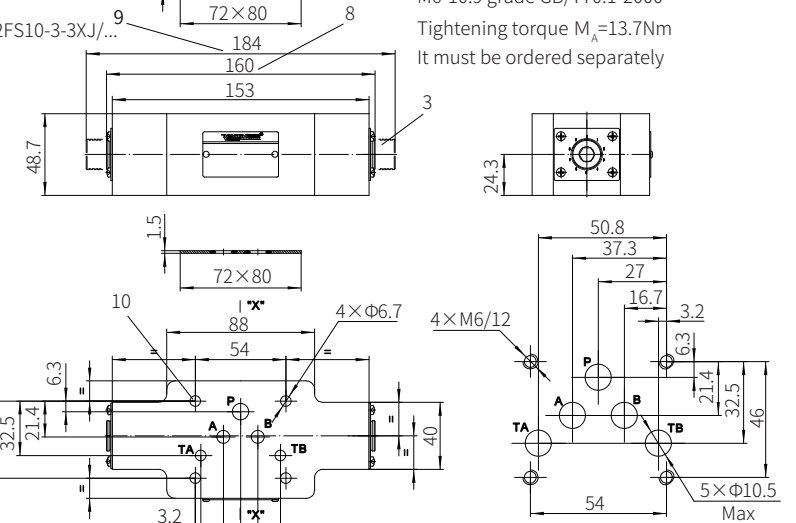

- 1 Name plate
- 2 Adjustment form "3"
- 3 Adjustment form "5"
- 4 Adjustment form "7"
- 5 Space required to remove key
- 6 O-ring plate
- 7 O-ring 12x2
- 8 Size for valve with minimum throttle port
- 9 Size for valve with maximum throttle port
- 10 Valve fixing screw hole
- 11 Rotate the valve 180° around the X-X axis to change it from meter-in to meter-out