

Modular Restrictive Check Valve

Model: Z2FS16...3XJ



- ◆ Size 16
- ◆ Maximum working pressure 315 bar
- ◆ Maximum working flow 250 L/min

Contents

Function description, sectional drawing	02
Models and specifications	02
Functional symbols	03
Technical parameters	03
Characteristic curve	04
Component size	05

Features

- Modular type valve
- Used to limit the main flow or control flow of two working oil ports
- Used for meter-in or meter-out control

Any part of this brochure can not be reproduced, edited, copied and disseminated electronically in any way without authorization of Jiayite Hydraulics company. As the product is in constant development and innovation, the information in this brochure is not specific to the special conditions or applicability of a specific industry, thus Jiayite Hydraulics company is not responsible for any incomplete or inaccurate description generated.



Function description, sectional drawing

The Z2FS16 type valve is a double throttle check valve with a stacked design. This valve is used to limit the main flow or control flow of one or two working oil ports. Two symmetrically arranged throttle check valves limit the flow in one direction (by adjusting the throttle valve core) and allow free flow in the opposite direction.

For meter-in control the oil fluid flows from oil port A to working oil port through the throttle port (1). The throttle spool (4.1) can be axially adjusted via the adjusting screw (5) to adjust throttle port (1). At the same time, the oil at port A flows through the channel (2) to the spring loading side (3) of the throttle spool (4.1), and results a pressure which force the throttle spool (4.1) in the throttle position together with the spring force.

The fluid flows back from the actuator to push the throttle spool (4.2) to allow oil flow freely and the valve acts as a check valve at this time. Depending on the model (S or S2), the throttle effect can be meter-in or meter-out control.

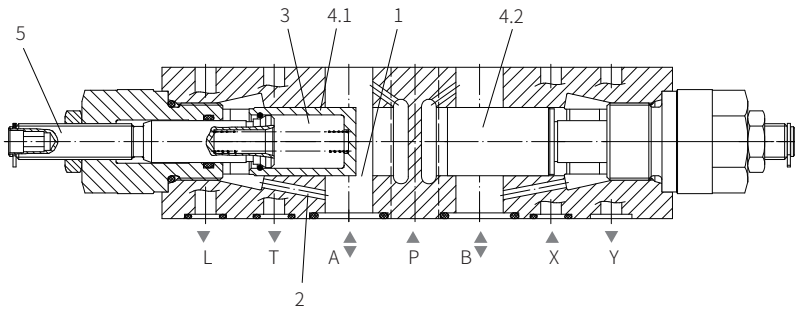

Model Z2FS16-3XJ/S...(meter-in control)

Models and specifications

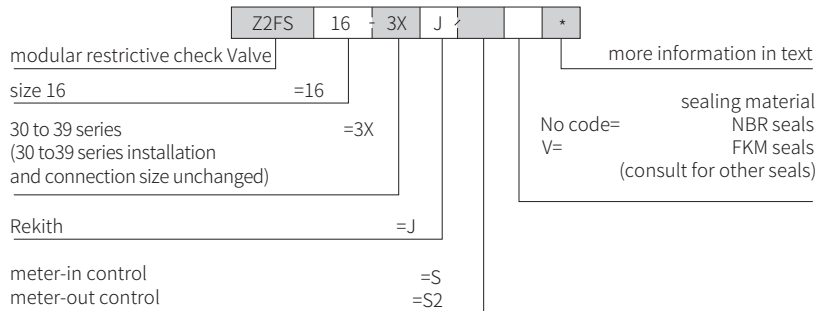

Functional symbols

(①=Valve side ②=Subplate side)

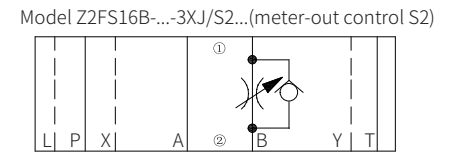
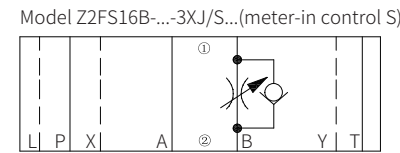
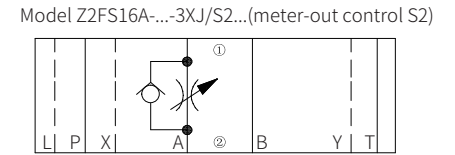
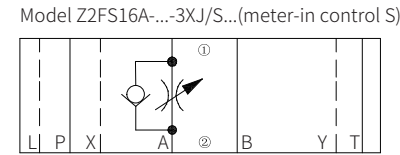
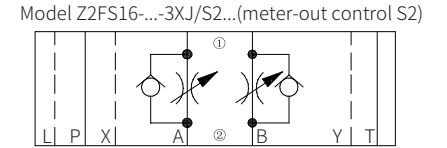
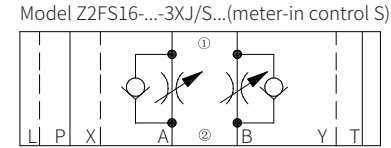

Technical parameters

Overview	
Installation position	Optional
Environment temperature range	°C -30 to +50 (NBR seal) -20 to +50 (FKM seal)
Weight	kg about 4.7
Hydraulic	
Maximum working pressure	bar to 315
Maximum flow	L/min to 250
Oil fluid	Mineral oil (HL, HLP) ¹⁾ in accordance with DIN 51524; Fast living organisms degraded oil according to VDMA 24568; HETG (Rapeseed oil) ¹⁾ ; HEPG (Polyethyleneglycol) ²⁾ ; HEES (Synthetic Fats) ²⁾
Pressure medium temperature range	°C -30 to +80 (NBR seal) -20 to +80 (FKM seal)
Viscosity range	mm ² /s 2.8 to 380
Cleanliness of oil ³⁾	The maximum allowable pollution level of oil is ISO4406 class 20 / 18 / 15

1) For NBR seal and FKM seal.

2) Only for FKM seal.

3) The oil must meet the cleanliness degree requested by the components in the hydraulic system. Effective oil filtration can prevent failure and increase the service life of the components.

Characteristic curve

(Measured when using HLP 46, $\vartheta_{oil} = 40^\circ\text{C} \pm 5^\circ\text{C}$)

The pressure drop Δp depends on the flow q_v through the check valve

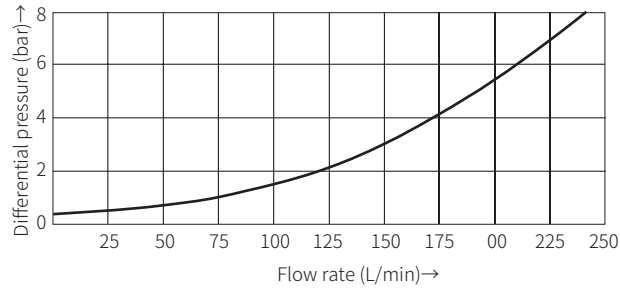

The pressure drop Δp depends on the flow q_v at a constant throttle setting

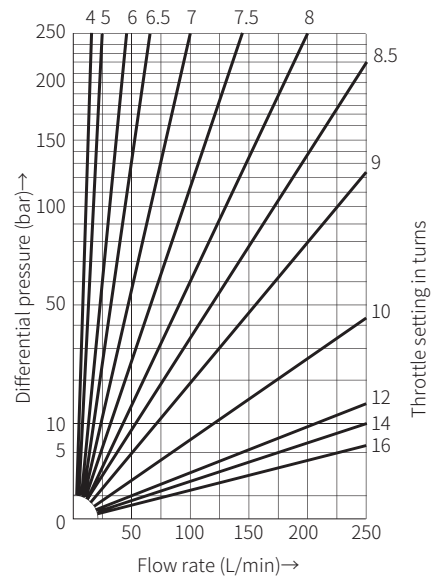

Component size

Size unit: mm

Model Z2FS16...-3XJ/...

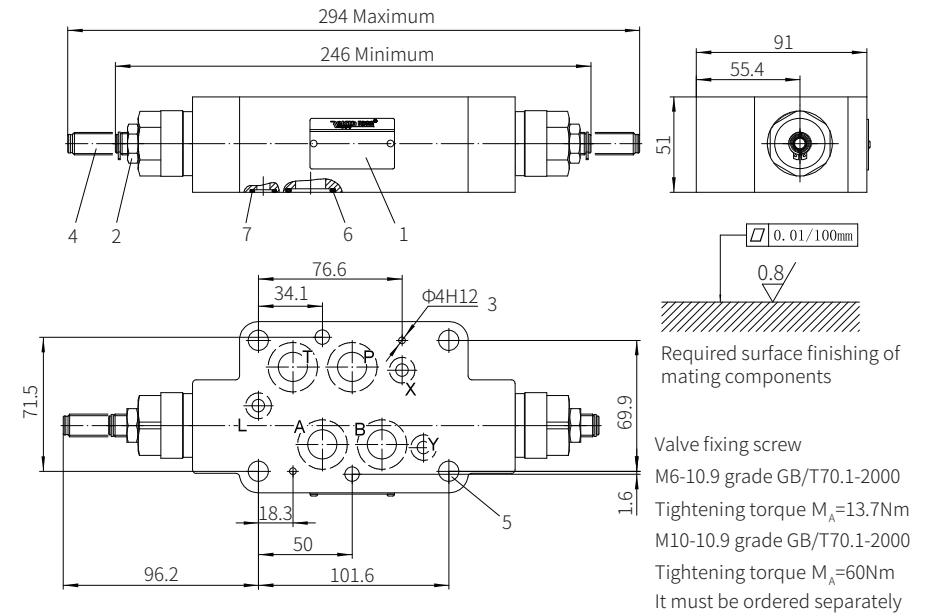

- 1 Name plate
- 2 Hexagon nut, SW=19
- 3 Two locating pin holes
- 4 Screw for changing flow cross-section (Inner hexagon screw, S=6)
Turn anti-clockwise= increases flow
Turn clockwise= decreases flow
- 5 Valve fixing screw hole
- 6 O ring 21.89x2.62 (for oil port P, A, B, T)
- 7 O ring 12x2 (for oil port X, Y, L)

