

Modular Restrictive Check Valve

Model: Z2FS22...3XJ



- ◆ Size 22
- ◆ Maximum working pressure 315 bar
- ◆ Maximum working flow 360 L/min

Contents

Function description, sectional drawing	02
Models and specifications	02
Functional symbols	03
Technical parameters	03
Characteristic curve	04
Component size	05

Features

- Modular type valve
- Used to limit the main flow or control flow of two working oil ports
- Used for meter-in or meter-out control

Any part of this brochure can not be reproduced, edited, copied and disseminated electronically in any way without authorization of Jiayite Hydraulics company. As the product is in constant development and innovation, the information in this brochure is not specific to the special conditions or applicability of a specific industry, thus Jiayite Hydraulics company is not responsible for any incomplete or inaccurate description generated.



Function description, sectional drawing

The Z2FS22 type valve is a double throttle check valve with a stacked design.

This valve is used to limit the main flow or control flow of one or two working oil ports. Two symmetrically arranged throttle check valves limit the flow in one direction (by adjusting the throttle valve core) and allow free flow in the opposite direction.

For meter-in control the oil fluid flows from port A to working oil port through the throttle port (1). The throttle spool (4.1) can be axially adjusted via the adjusting screw (5) to adjust throttle port (1). At the same time, the oil at port A flows through the channel (2) to spring loading side (3) of the throttle spool (4.1), and results a pressure which force the throttle spool (4.1) in the throttling position together with the spring force.

The fluid flows back flow from the actuator to push the throttle spool (4.2) to allow oil flow freely and the valve acts as a check valve at this time. Depending on the model (S or S2), the throttle effect can be meter-in or meter-out control.

Main flow limit

To change velocity of the actuator, the double throttle check valve is installed between the subplate and the directional valve.

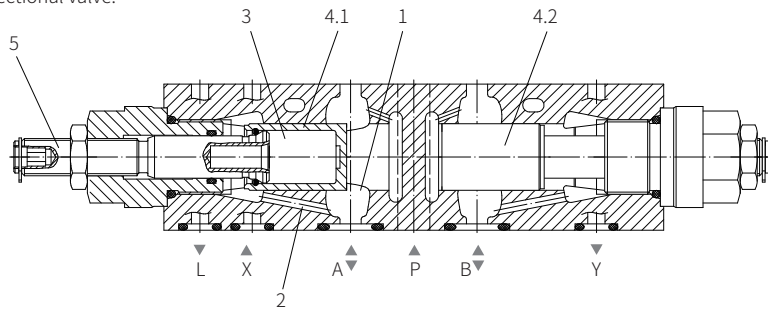

Model Z2FS22-3XJ/S... (meter-in control)

Models and specifications

Z2FS	22	3X	J	*
modular restrictive check Valve	=22	=3X	=J	more information in text
size 22				sealing material
30 to 39 series				No code= NBR seals
(30 to 39 series installation and connection size unchanged)				V= FKM seals
Rekith				(consult for other seals)
meter-in control			=S	
meter-out control			=S2	

Functional symbols

(①=Valve side ②=Subplate side)

Model Z2FS22-...-3XJ/S...(meter-in control S)

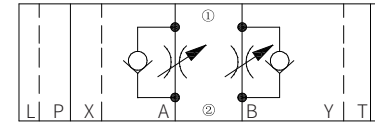

Model Z2FS22-...-3XJ/S2...(meter-out control S2)

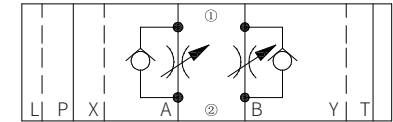

Model Z2FS22A-...-3XJ/S...(meter-in control S)

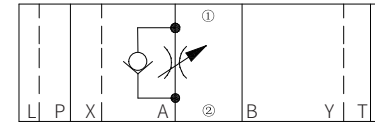

Model Z2FS22A-...-3XJ/S2...(meter-out control S2)

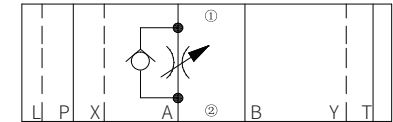

Model Z2FS22B-...-3XJ/S...(meter-in control S)

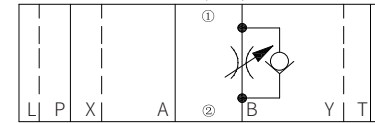

Model Z2FS22B-...-3XJ/S2...(meter-out control S2)

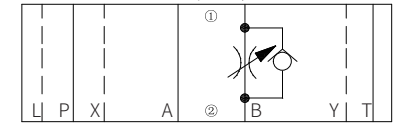

Technical parameters

Overview		Optional
Installation position		
Environment temperature range	°C	-30 to +50 (NBR seal) -20 to +50 (FKM seal)
Weight	kg	about 8
Hydraulic		
Maximum working pressure	bar	to 315
Maximum flow	L/min	to 360
Oil fluid		Mineral oil (HL, HLP) ¹⁾ in accordance with DIN 51524; Fast living organisms degraded oil according to VDMA 24568; HETG (Rapeseed oil) ¹⁾ ; HEPG (Polyethyleneglycol) ²⁾ ; HEES (Synthetic Fats) ²⁾
Pressure medium temperature range	°C	-30 to +80 (NBR seal) -20 to +80 (FKM seal)
Viscosity range	mm ² /s	2.8 to 380
Cleanliness of oil ³⁾		The maximum allowable pollution level of oil is ISO4406 class 20 / 18 / 15

1) For NBR seal and FKM seal.

2) Only for FKM seal.

3) The oil must meet the cleanliness degree requested by the components in the hydraulic system. Effective oil filtration can prevent failure and increase the service life of the components.

Characteristic curve

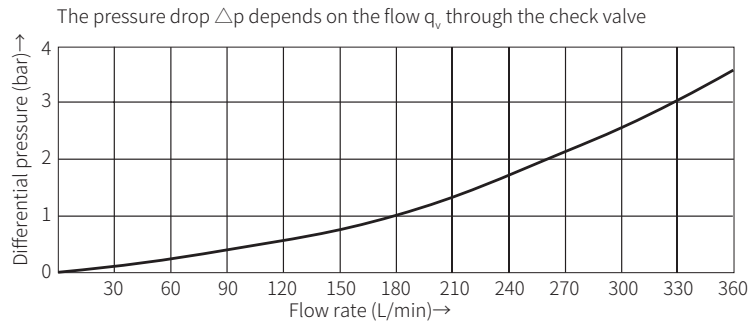
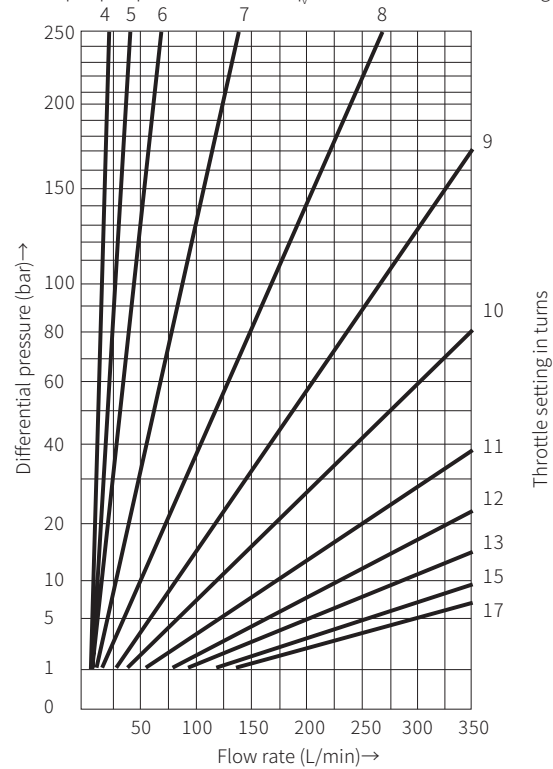
(Measured when using HLP 46, $\vartheta_{oil} = 40^\circ\text{C} \pm 5^\circ\text{C}$)The pressure drop Δp depends on the flow q_v at a constant throttle setting

Component size

Size unit: mm

Model Z2FS22...-3XJ/...

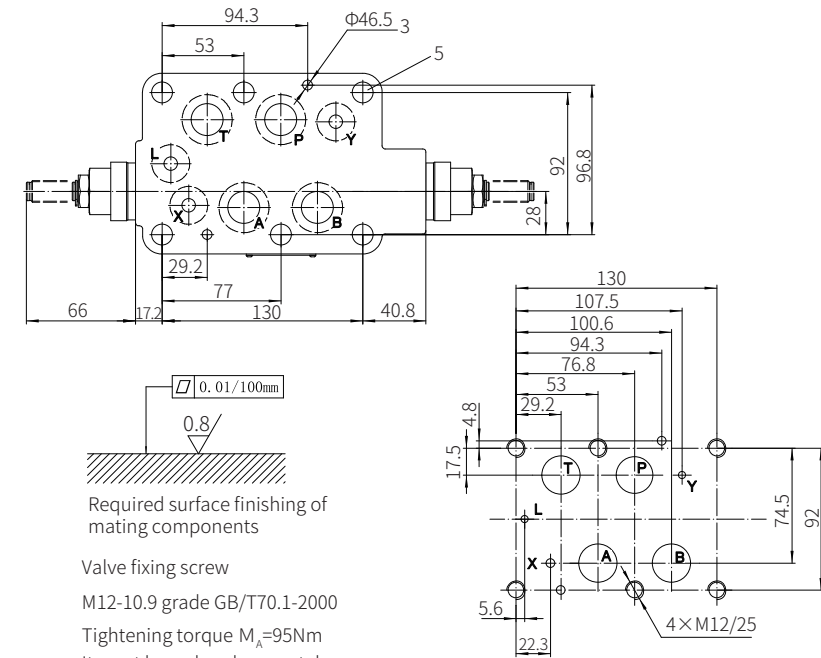
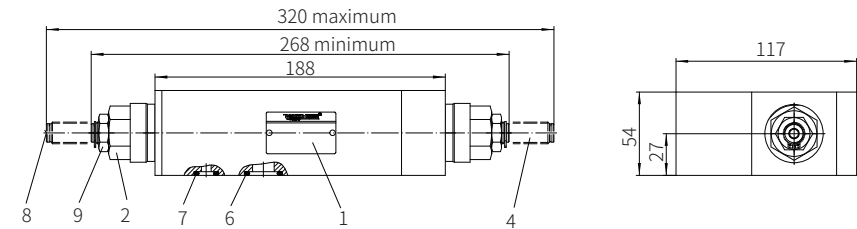

- 1 Name plate
- 2 Hexagon nut, SW=22
- 3 Two locating pin holes
- 4 Screw for changing flow cross-section
Turn anti-clockwise= increases flow
Turn clockwise= decreases flow

- 5 Valve fixing screw hole
- 6 O ring 27×3
(for oil port P, A, B, T)
- 7 O ring 19×3
(for oil port X, Y, L)
- 8 Inner hexagon screw, S=6